

HOOD TYPE MACHINE

INSULATED HOOD
ELECTRONICAL CONTROL

TYPE: 130HE

Accessories
HOOD LIFTING SYSTEM
BREAK TANK
BOOSTER PUMP
DVGW
WATER SOFTNER
DETERGENT DISPENSER
DRAIN PUMP

Spare parts manual

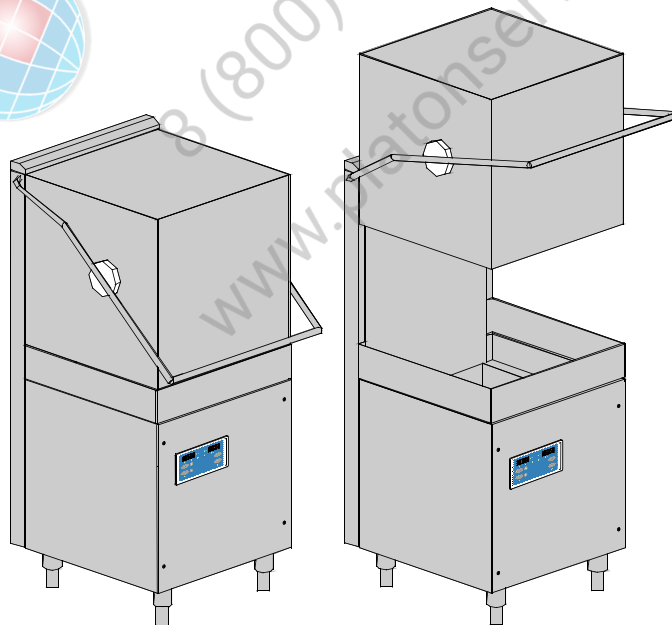

INFORMAZIONI GENERALI

Questo catalogo serve per richiedere con esattezza le parti di ricambio

Nelle ordinazioni indicare:

1) il numero dei codici dei particolari seguito dalla descrizione e la quantità desiderata;

2) Il codice alfa-numerico presente nella seconda colonna della tabella ;

I disegni delle parti di ricambio sono solo indicativi e non rappresentano il pezzo in oggetto.

I dati contenuti in questo catalogo sono indicativi e possono essere soggetti a modifiche senza impegno di preavviso.

ALLGEMEINE INFORMATIONEN

Dieser Ersatzteilkatalog dient zur genauen Angabe der Teile bei Ersatzteilbestellungen.

Bei Ersatzbestellung ist folgendes anzugeben:

1) Die Bestellnummer der Ersatzteile mit der entsprechenden Beschreibung genaue Menge;

2) Der alpha-numerischer Code auf der zweiten Reihe in dein Spalte;

Die Zeichnungen der Ersatzteile sind nur als Hinweise gedacht und stellen nicht das betroffene Teil dar.

Bei den im Katalog angeführten Daten handelt es sich um Anhaltsdaten, die jederzeit, ohne Vorankündigung, geändert werden können.

GENERAL INFORMATION

The present spare parts order exactly the right spare parts

When ordering specify:

1) the part's code number followed by its description and quantity needed;

2) The alpha-numeric code is in the second column in the chart;

Spare parts drawings are general and do not represent the part.

The contents of this catalogue are general and can undergo changes without prior notice.

INFORMACIONES GENERALES

El presente catálogo sirve para pedir con exactitud las partes de repuesto

En los pedidos se debe indicar:

1) el número de código de la parte y a continuación la descripción cantidad deseada;

2) El código alfanumerico presente en la signada columna de la tabla;

Los diseños de las partes de recambio son solo indicativos y no representan la pieza en cuestión.

Los datos contenidos en el presente catálogo son indicativos y pueden modificarse sin aviso previo.

INFORMATIONS GENERALES

Ce catalogue permet de commander correctement les pièces détachées

Les commandes doivent être passées en indiquant:

1) le numero de code des pièces détachées suivi de leur description quantité désirée;

2) le code alphanumérique dans la deuxième colonne du tableau;

Les plans des pièces détachées sont fournis seulement à titre indicatif et ne représentent pas la pièce concernée.

Les données de ce catalogue sont citées seulement à titre indicatif et peuvent être l'objet de modifications sans avis préalable.

ESEMPIO
EXAMPLE
EXEMPLE
BEISPIEL

Rif.	Codici
MODULE:Particolari	
10505	540903
10510	540908
10515	15065/A
10520	540086
10525	540028

 **Note**

Tutte le informazioni riportate si intendono aggiornate alla data di stampa. Il Produttore si riserva il diritto di apportare qualsiasi modifica richiesta dallo sviluppo evolutivo dei suddetti prodotti.

Per la sicurezza, la garanzia, l'affidabilità ed il valore della lavastoviglie usa solo ricambi originali. **Per alcuni codici, sono richieste quantità minime d'ordine.**

 **Attenzione**

Questo libretto è parte integrante della lavastoviglie e, in caso di passaggio di proprietà, deve essere consegnato al nuovo acquirente.

 **Note**

The information contained herein is valid at the time of going to print. The Company reserves the right to make any changes required by the future development of the above-mentioned products.

For your safety, as well as to preserve the warranty reliability and worth of your dishwashers, use original spare parts only. **For some codes a minimum quantity for order is required.**

 **Warning**

This manual forms an integral part of the dishwashers and - if a transfer of title occurs - must always be handed over to the new owner.

 **Remarque**

Toutes les informations contenues dans ce manuel s'entendent mises à jour à la date d'impression. En raison du développement constant de ses produits, usine se réserve le droit d'apporter à tout instant les modifications qu'elle jugera utiles.

Pour la sécurité, la garantie, la fiabilité et la valeur de votre lavevaisselles n'utilisez que des pièces de rechange d'origine. **Pour quelque référence on demande un minimum de pièces par commande**

 **Attention**

Ce manuel doit être considéré comme partie intégrante de la lavevaisselles, en cas de transfert de propriété, doit toujours être remis au nouveau propriétaire.

 **Hinweis**

Die Der Hersteller behält sich das Recht vor, jegliche, durch eine Weiterentwicklung der genannten Produkte bedingte Änderungen vornehmen zu können.

Verwenden Sie für Ihre Sicherheit, die Garantie, die Zuverlässigkeit und den Wert Ihrer machine originale Ersatzteile. **Für bestimmte Code nummer werden mindesten bestellungen verlangt.**

 **Achtung**

Diese Betriebsanleitung ist Bestandteil des machine und muss bei seinem Weiterverkauf dem neuen Besitzer ausgehändigt werden.





Code 999XYYYY **CL/Part**

Model DESCRIPTION 

S/N 04012345 **Type**

400VAC3N 50HZ 8A
3500W 500W

  16A

200-500

Pressione Dinamica alimentazione idrica
Pression dynamique arrivee d'eau
Dynamic pressure water supply
Dynamischer Druck asserreinlauf

Pressione dinamica vapore saturo
Pression dynamique vapeur satuee
Dymanischer Druck gesattigter Dampf
Pression Dinamica Vapor Saturado

TECHICAL SPECIFICATION

MADE IN ITALY

Temperatura massima acqua in ingresso **60°C**
Temperature max eau a l'entre
Maximale Temperatur Wasseranschlu
Maximum Water temperature in-feeding

Model 

S/N 

CODE 999 XX YYYY



FAMIGLIA PRODOTTO
FAMILY PRODUCT
FAMILLE DU PRODUIT
FAMILIA PRODUCTO
FAMILIE DES PRODUKTES

CODICE MODELLO
CODE MODEL
CODE ARTICLE
CODIGO MODELO
KODE VON MODELL

S/N 04 012345

ANNO
YEAR
ANNÉE
AN^o
JAHR

NUMERO DI SERIE
SERIAL NUMBER
NUMÉRO DI SÉRIE
NUMERO DI SERIE
SERIENNUMMER



PLATONSERVICE

8 (800) 500-34-41

www.platonservice.com

1. Spare parts

General body parts.....	7
Closing panelig.....	9
Hood LIFT lifting system	13
Control panel and switches.....	17
Electric control components.....	19
Solenoid valve group	21
Solenoid valve group	23
Break Tank	25
Rinse with steady temperature.....	27
DVGW	29
Water softner group.....	31
Rinse aid dispenser group.....	33
Boiler group	35
3 ways connection	37
Wash pump group.....	39
Dosing detergent group.....	41

Drain pump group..... 43

Pressure switch group with air trap ... 45

Turret group with rotating arms 47



PLATON SERVICE

8 (800) 500-34-41

www.platonservice.com

1.1 Voltage codes

Volt	Voltage code
A	3/N/PE~380-400V 50-60Hz
D	3/PE~200-210V 50-60Hz
F	2/PE~220-240V 50-60Hz
G	3/N/PE~415V 50-60Hz
H	3/PE~220-230V 50-60Hz
K	3/PE~380-400V 50-60Hz
L	3/PE~415V 50-60Hz
M	3/PE~440V 60Hz
P	1/N/PE~220-230V 50-60Hz
R	2/PE~220-240V 50-60Hz
U	1/N/PE~240V 50-60Hz
V	3/PE~240V 50-60Hz
W	1/N/PE~100-110V 50-60Hz

1.2 Product codes

Product code	Full name
Model codes	
i	INSULATED HOOD
e	ELECTRONICAL CONTROL
Type codes	
130HE	130HE
Accessory codes	
lift	HOOD LIFTING SYSTEM
bt	BREAK TANK
bp	BOOSTER PUMP
dvgw	DVGW
ws	WATER SOFTNER
dd	DETERGENT DISPENSER
dp	DRAIN PUMP

01_028_e

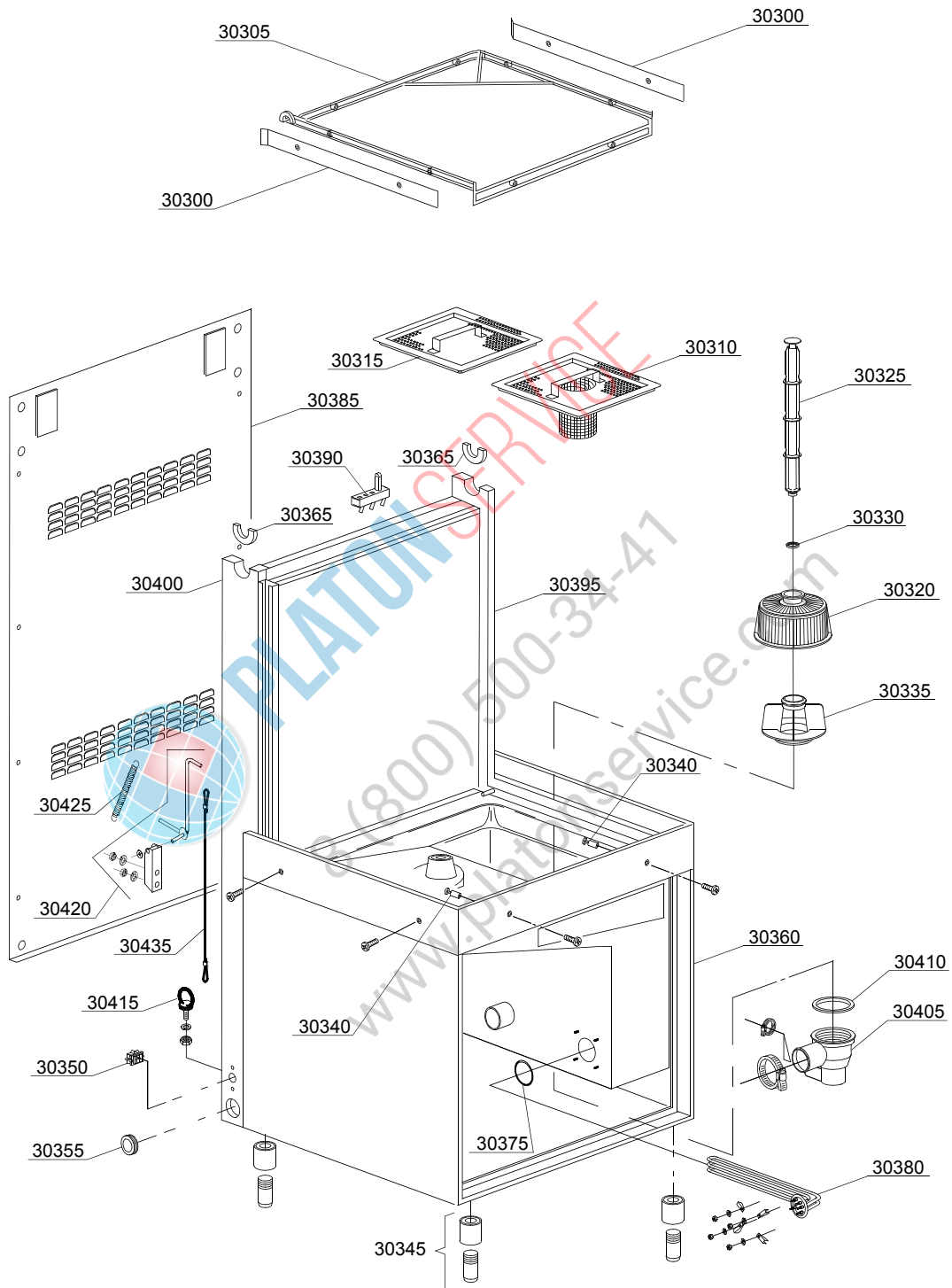

Spare parts

ID	P-code	SN from	SN to	Mod.	Acces.	Volt	Description
Module:General body parts							
30300	10600923		-				Guide rail
30305	11600001		-				Rack frame
30310	11600906		-				Strainer plate with a strainer box
30315	11600907		-				Strainer plate
30320	500616		-				Suction filter
30325	11600102		-				Overflow pipe
30330	13021		-				DEM 40 O-ring
30335	500615		-				Ferrule with filter
30340	11600018		-				Basket support holder pin
30345	15116		-				Foot
30350	15065/A		-				Cable-fastener with screw
30355	13324		-				Cable screw cap
30360	11600960		-				Frame assembly
30365	11600055		-				Right/left slide bearing
30375	13015		-				O-ring
30380	15047/A		-				2,7/2,94KW 230/240V 3 heating element
30385	11600630		-				Back panel
30390	70305		-				Hood switch
30395	11600620		-				Right guide rail support
30400	11600621		-				Left guide rail support
30405	500605		-				Outlet connction
30410	80208		-				95x75x3 O-ring
30415	11600058		-				Passage ring for the security cord
30420	11600059		-				Support for the security system assembly
30425	10700		-				Spring
30435	1160057/A		-				Secury system cord

i=INSULATED HOOD, e=ELECTRONICAL CONTROL

130HE=130HE

lift=HOOD LIFTING SYSTEM, bt=BREAK TANK, bp=BOOSTER PUMP, dvgw=DVGW, ws=WATER SOFTNER, dd=DETERGENT DISPENSER, dp=DRAIN PUMP

A=3/N/PE~380-400V 50-60Hz, D=3/PE~200-210V 50-60Hz, F=2/PE~220-240V 50-60Hz, G=3/N/PE~415V 50-60Hz, H=3/PE~220-230V 50-60Hz, K=3/PE~380-400V 50-60Hz, L=3/PE~415V 50-60Hz, M=3/PE~440V 60Hz, P=1/N/PE~220-230V 50-60Hz, R=2/PE~220-240V 50-60Hz, U=1/N/PE~240V 50-60Hz, V=3/PE~240V 50-60Hz, W=1/N/PE~100-110V 50-60Hz

02a202_e

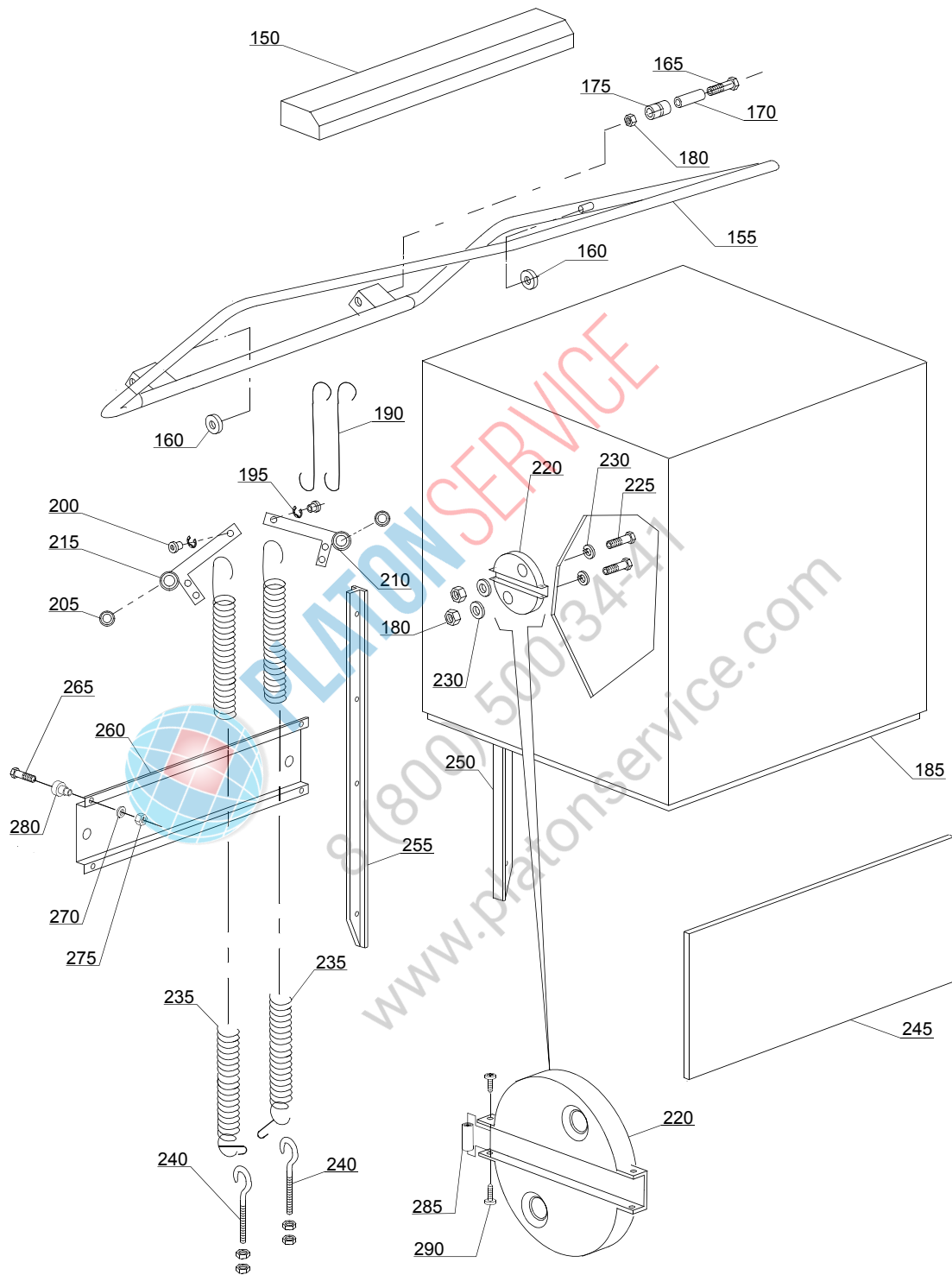

Spare parts

ID	P-code	SN from	SN to	Mod.	Acces.	Volt	Description
Module:Closing panelig							
150	11600913		-				Guide
155	11600910		-				Handle
160	89919		-				Bearing
165	11214		-				Screw
170	11600015		-				Filter
175	11600014		-				Roller
180	11718		-				M8 stainless steel self-locking nut
185	11600902		-				Hood, complete
190	11600013		-				Hook
200	11600038		-				Spring bush
205	10800010		-				Bearing 6002 2RS
210	11600026		-				Elbow, right
215	11600027		-				Elbow, left
220	11600036		-				Bearing holder
225	11110		-				Screw
230	13301		-				Gasket Ø 14x8x1,5
235	70302		-				Hood spring
240	10800210		-				Hook screw
245	11600616		-				Front plate
245	11600953		-				Lower front panel
250	11600028		-				Guide, right
255	11600029		-				Guide, left
260	11600624		-				Leavers bearing foor hood
265	11134		-				M10x35 TE Stainless steel screw
270	11192		-				M10 Stainless steel epring washer
275	11719		-				M10 inox nut
280	10800115		-				Lifting rod pin
285	76251		-				Spacer

i=INSULATED HOOD, e=ELECTRONICAL CONTROL

130HE=130HE

lift=HOOD LIFTING SYSTEM, bt=BREAK TANK, bp=BOOSTER PUMP, dvgw=DVGW, ws=WATER SOFTNER, dd=DETERGENT DISPENSER, dp=DRAIN PUMP

A=3/N/PE~380-400V 50-60Hz, D=3/PE~200-210V 50-60Hz, F=2/PE~220-240V 50-60Hz, G=3/N/PE~415V 50-60Hz, H=3/PE~220-230V 50-60Hz, K=3/PE~380-400V 50-60Hz, L=3/PE~415V 50-60Hz, M=3/PE~440V 60Hz, P=1/N/PE~220-230V 50-60Hz, R=2/PE~220-240V 50-60Hz, U=1/N/PE~240V 50-60Hz, V=3/PE~240V 50-60Hz, W=1/N/PE~100-110V 50-60Hz

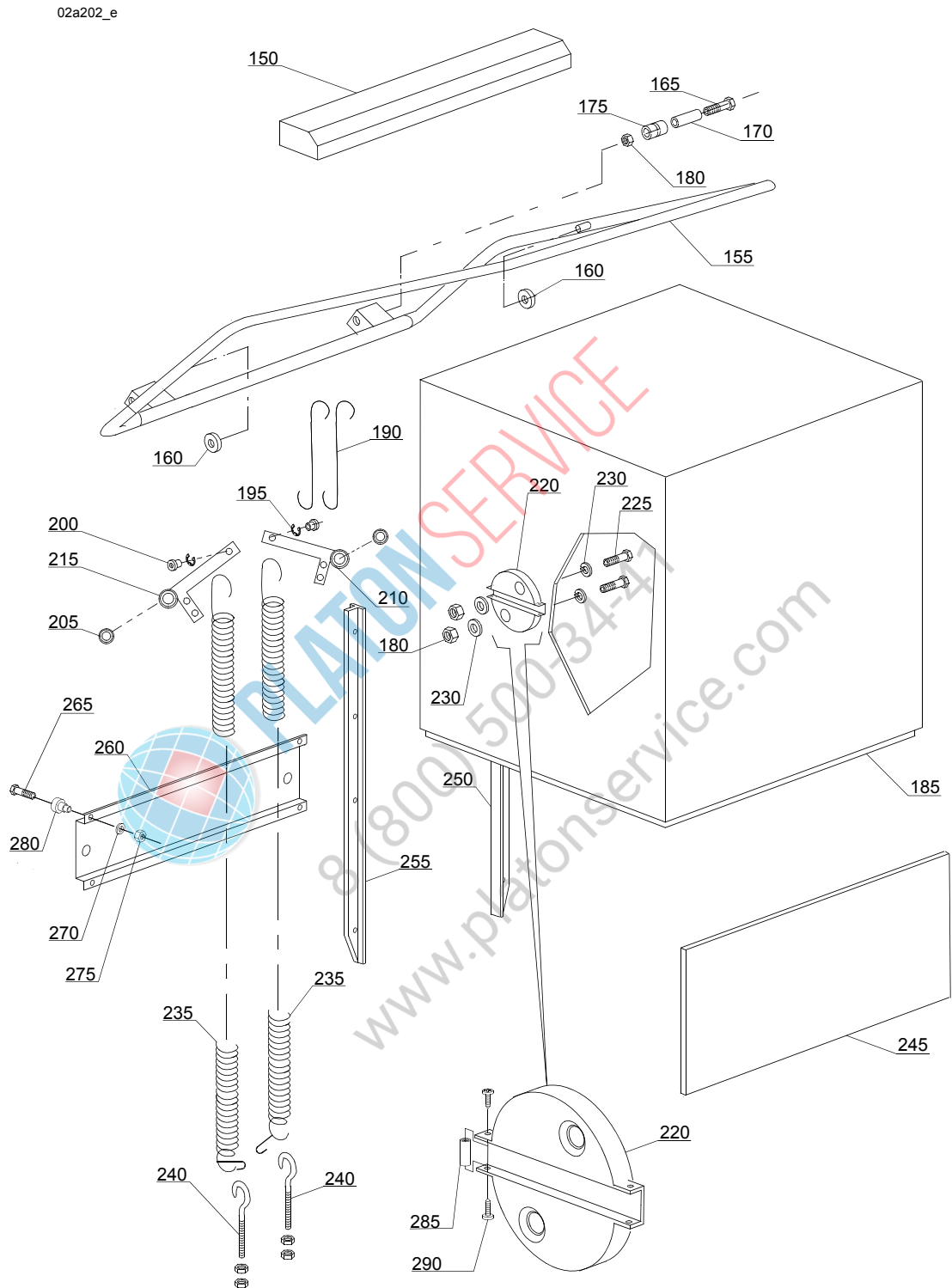

Spare parts

ID	P-code	SN from	SN to	Mod.	Acces.	Volt	Description
Module:Closing panelig							
290	11121		-				M4x10 TCB Inox screw

i=INSULATED HOOD, e=ELECTRONICAL CONTROL

130HE=130HE

lift=HOOD LIFTING SYSTEM, bt=BREAK TANK, bp=BOOSTER PUMP, dvgw=DVGW, ws=WATER SOFTNER, dd=DETERGENT DISPENSER, dp=DRAIN PUMP

A=3/N/PE~380-400V 50-60Hz, D=3/PE~200-210V 50-60Hz, F=2/PE~220-240V 50-60Hz, G=3/N/PE~415V 50-60Hz, H=3/PE~220-230V 50-60Hz, K=3/PE~380-400V 50-60Hz, L=3/PE~415V 50-60Hz, M=3/PE~440V 60Hz, P=1/N/PE~220-230V 50-60Hz, R=2/PE~220-240V 50-60Hz, U=1/N/PE~240V 50-60Hz, V=3/PE~240V 50-60Hz, W=1/N/PE~100-110V 50-60Hz



PLATON SERVICE

8 (800) 500-34-41

www.platonservice.com

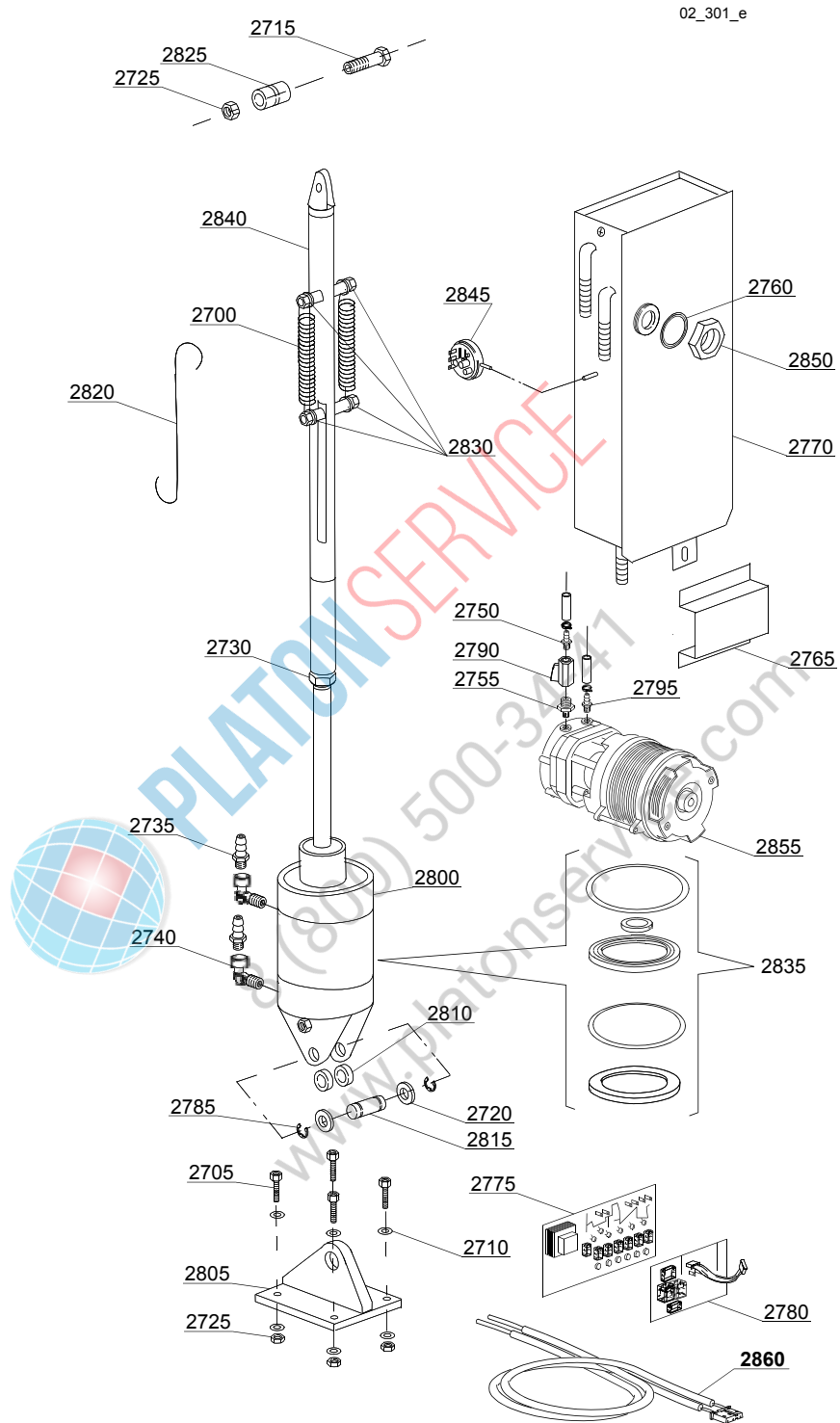

Spare parts

ID	P-code	SN from	SN to	Mod.	Acces.	Volt	Description
Module:Hood LIFT lifting system							
2700	10700		-		lift		Spring
2705	11166		-		lift		Screw
2710	11177		-		lift		Plain washer
2715	11215		-		lift		Screw
2720	11617		-		lift		Washer
2725	11718		-		lift		M8 stainless steel self-locking nut
2730	11720		-		lift		M16 stainless steel nut
2735	12005		-		lift		Rubber-holder
2740	12012		-		lift		M/F 1/4 Elbow
2750	12013		-		lift		Hose coupling - 10mm - 3/8"
2755	12034		-		lift		Reduction nipple 3/8" - 1/2"
2760	13305		-		lift		44x32x3 O-ring
2765	15738		-		lift		Overflow cover
2770	15745		-		lift		Water receiver
2775	50569		-		lift		Electronic Card without Chip
2780	50559		-		lift		Circuit board DP
2785	3002069		-		lift		Stainless steel snap ring
2790	3002140		-		lift		FF 1/2 tap
2795	10221311		-		lift		Hose coupling - 12mm - 3/8"
2800	11600042		-		lift		Hydraulic piston
2805	11600043		-		lift		Flange for piston
2810	11600044		-		lift		Spacer for flange joint
2815	11600045		-		lift		Piston axel pin for flange
2820	11600046		-		lift		Piston movement bar
2825	11600047		-		lift		Strengthened bushing
2830	11600049		-		lift		Pins spring attachment
2835	11600053		-		lift		Gasket kit hydraulic piston
2840	11600917		-		lift		Piston lifting arm

i=INSULATED HOOD, e=ELECTRONICAL CONTROL

130HE=130HE

lift=HOOD LIFTING SYSTEM, bt=BREAK TANK, bp=BOOSTER PUMP, dvgw=DVGW, ws=WATER SOFTNER, dd=DETERGENT DISPENSER, dp=DRAIN PUMP

A=3/N/PE~380-400V 50-60Hz, D=3/PE~200-210V 50-60Hz, F=2/PE~220-240V 50-60Hz, G=3/N/PE~415V 50-60Hz, H=3/PE~220-230V 50-60Hz, K=3/PE~380-400V 50-60Hz, L=3/PE~415V 50-60Hz, M=3/PE~440V 60Hz, P=1/N/PE~220-230V 50-60Hz, R=2/PE~220-240V 50-60Hz, U=1/N/PE~240V 50-60Hz, V=3/PE~240V 50-60Hz, W=1/N/PE~100-110V 50-60Hz

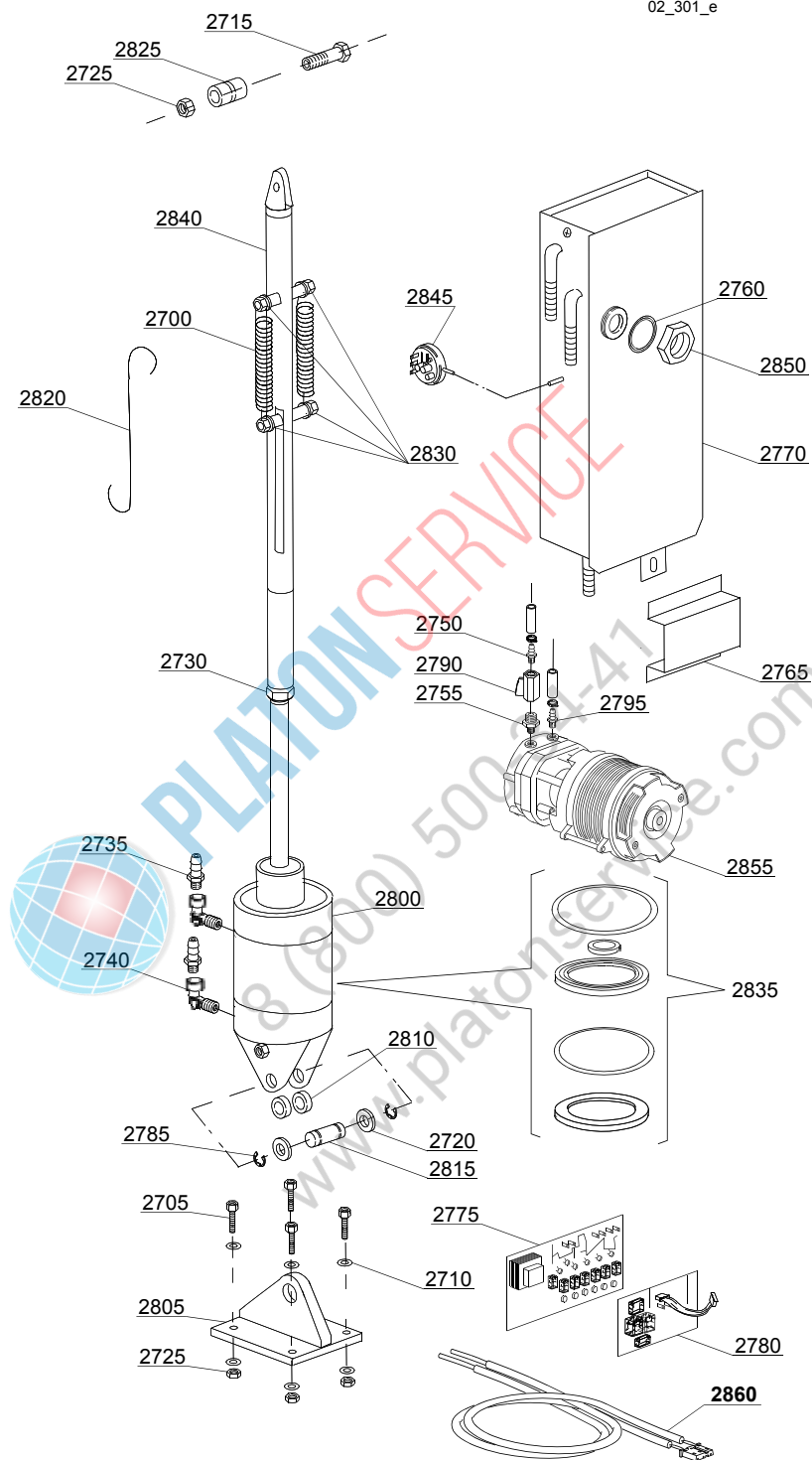

Spare parts

ID	P-code	SN from	SN to	Mod.	Acces.	Volt	Description
Module:Hood LIFT lifting system							
2845	10706/A		-		lift		47-27 pressure switch
2850	11701/A		-		lift		Stainless steel nut
2855	15100/D		-		lift		Booster pump 220-240V 50Hz
2860	50562		-		lift		Sensor

i=INSULATED HOOD, e=ELECTRONICAL CONTROL

130HE=130HE

lift=HOOD LIFTING SYSTEM, bt=BREAK TANK, bp=BOOSTER PUMP, dvgw=DVGW, ws=WATER SOFTNER, dd=DETERGENT DISPENSER, dp=DRAIN PUMP

A=3/N/PE~380-400V 50-60Hz, D=3/PE~200-210V 50-60Hz, F=2/PE~220-240V 50-60Hz, G=3/N/PE~415V 50-60Hz, H=3/PE~220-230V 50-60Hz, K=3/PE~380-400V 50-60Hz, L=3/PE~415V 50-60Hz, M=3/PE~440V 60Hz, P=1/N/PE~220-230V 50-60Hz, R=2/PE~220-240V 50-60Hz, U=1/N/PE~240V 50-60Hz, V=3/PE~240V 50-60Hz, W=1/N/PE~100-110V 50-60Hz



PLATON SERVICE
 8 (800) 500-34-41
 www.platonservice.com

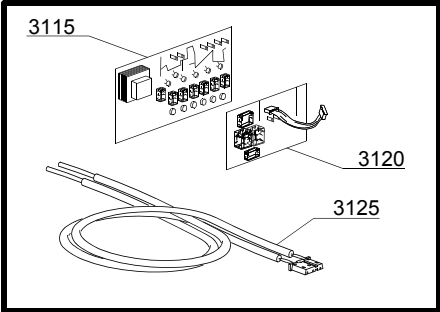
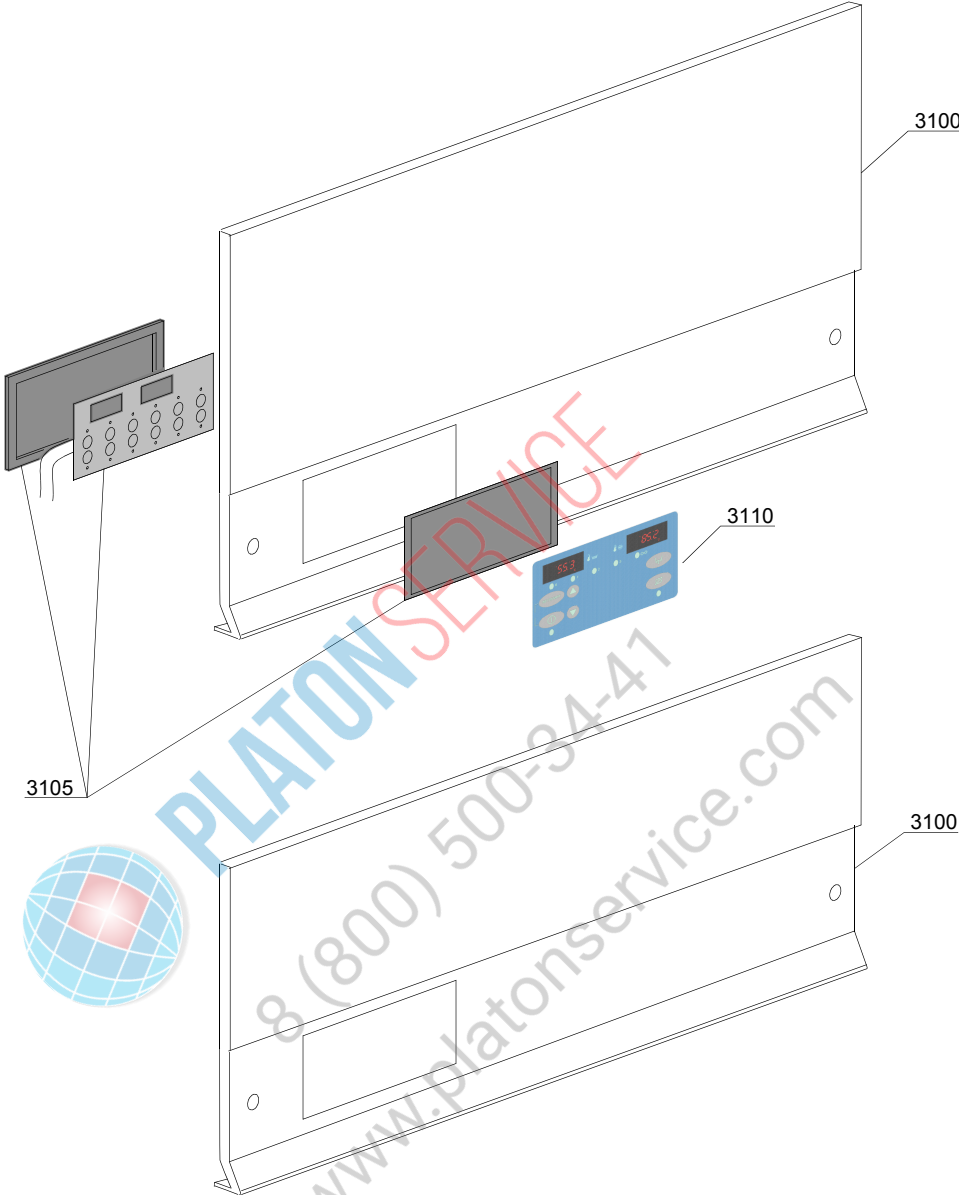

Spare parts

ID	P-code	SN from	SN to	Mod.	Acces.	Volt	Description
Module:Control panel and switches							
3100	11600952		-	e			Control panel
3105	50570		-	e			Compleat membrane push button-driver
3105	50570/B		-	e			Compleat membrane push button-driver PLUS
3110	50578		-	e	dp,ws		Silkscreen processed grill membrane push button-driver dp+ws
3115	50569		-	e			Electronic card without chip
3120	50559		-	e			Circuit board DP
3125	50562		-	e			Sensor

i=INSULATED HOOD, e=ELECTRONICAL CONTROL

130HE=130HE

lift=HOOD LIFTING SYSTEM, bt=BREAK TANK, bp=BOOSTER PUMP, dvgw=DVGW, ws=WATER SOFTNER, dd=DETERGENT DISPENSER, dp=DRAIN PUMP

A=3/N/PE~380-400V 50-60Hz, D=3/PE~200-210V 50-60Hz, F=2/PE~220-240V 50-60Hz, G=3/N/PE~415V 50-60Hz, H=3/PE~220-230V 50-60Hz, K=3/PE~380-400V 50-60Hz, L=3/PE~415V 50-60Hz, M=3/PE~440V 60Hz, P=1/N/PE~220-230V 50-60Hz, R=2/PE~220-240V 50-60Hz, U=1/N/PE~240V 50-60Hz, V=3/PE~240V 50-60Hz, W=1/N/PE~100-110V 50-60Hz



PLATON SERVICE
8 (800) 500-34-41
www.platonservice.com

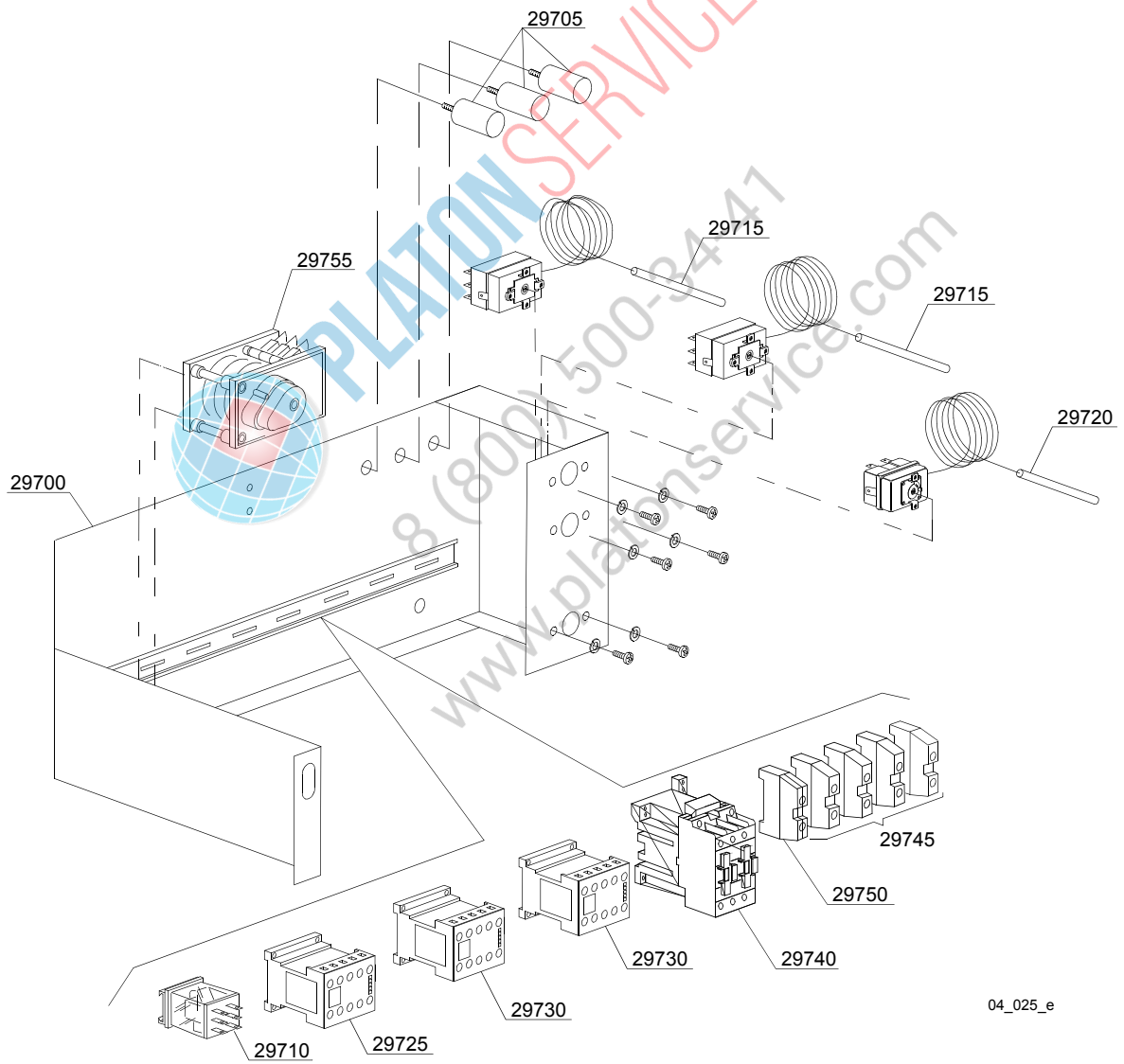
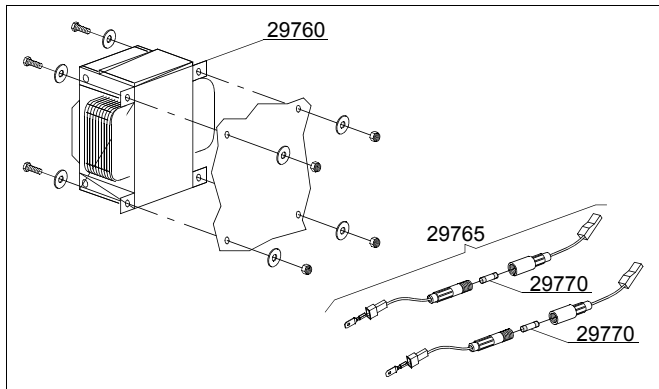

04_025_e

Spare parts

ID	P-code	SN from	SN to	Mod.	Acces.	Volt	Description
Module:Electric control components							
29700	11600955		-	e			Electric component panel
29705	15149		-	e			Low noise filter
29710	560301		-	e	lift		Relay 230V 50/60Hz
29720	2000430		-	e			Overheat protector
29725	10300392		-	e			3NA/1NC contactor - 240Vac 50Hz
29730	15086		-	e			Contactor TLV, TLB
29730	15086/B		-	e			Contactor 240V 50Hz
29740	10300050		-	e			Contactor TLP
29740	10300052		-	e			36A/20A contactor - 230V 50/60HZ
29740	10300054		-	e			25A/16A contactor - 230V 50/60HZ
29745	10300401		-	e			Connecting piece
29750	10300403		-	e			Connecting piece

i=INSULATED HOOD, e=ELECTRONICAL CONTROL

130HE=130HE

lift=HOOD LIFTING SYSTEM, bt=BREAK TANK, bp=BOOSTER PUMP, dvgw=DVGW, ws=WATER SOFTNER, dd=DETERGENT DISPENSER, dp=DRAIN PUMP

A=3/N/PE~380-400V 50-60Hz, D=3/PE~200-210V 50-60Hz, F=2/PE~220-240V 50-60Hz, G=3/N/PE~415V 50-60Hz, H=3/PE~220-230V 50-60Hz, K=3/PE~380-400V 50-60Hz, L=3/PE~415V 50-60Hz, M=3/PE~440V 60Hz, P=1/N/PE~220-230V 50-60Hz, R=2/PE~220-240V 50-60Hz, U=1/N/PE~240V 50-60Hz, V=3/PE~240V 50-60Hz, W=1/N/PE~100-110V 50-60Hz



PLATON SERVICE
8 (800) 500-3477
www.platonservice.com

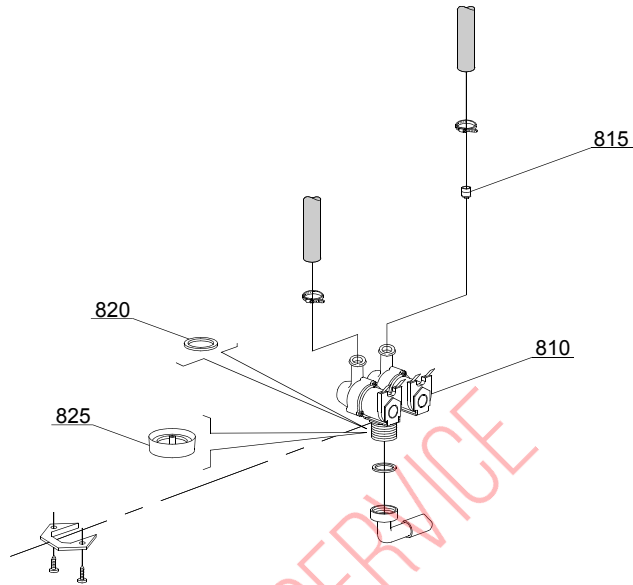

05_003_e



PLATON SERVICE
8 (800) 500-34-41
www.platonservice.com

Spare parts

ID	P-code	SN from	SN to	Mod.	Acces.	Volt	Description
Module:Solenoid valve group							
810	15098		-	i	ws		Double solenoid valve - Ø10
820	N.C.		-	i	ws		Pression reducing valve

i=INSULATED HOOD, e=ELECTRONICAL CONTROL

130HE=130HE

lift=HOOD LIFTING SYSTEM, bt=BREAK TANK, bp=BOOSTER PUMP, dvgw=DVGW, ws=WATER SOFTNER, dd=DETERGENT DISPENSER, dp=DRAIN PUMP

A=3/N/PE~380-400V 50-60Hz, D=3/PE~200-210V 50-60Hz, F=2/PE~220-240V 50-60Hz, G=3/N/PE~415V 50-60Hz, H=3/PE~220-230V 50-60Hz, K=3/PE~380-400V 50-60Hz, L=3/PE~415V 50-60Hz, M=3/PE~440V 60Hz, P=1/N/PE~220-230V 50-60Hz, R=2/PE~220-240V 50-60Hz, U=1/N/PE~240V 50-60Hz, V=3/PE~240V 50-60Hz, W=1/N/PE~100-110V 50-60Hz



PLATON SERVICE

8 (800) 500-34-41

www.platonservice.com

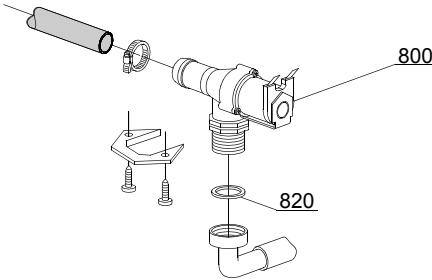

05_005_e

PLATON SERVICE
8 (800) 500-34-41
www.platonservice.com

Spare parts

ID	P-code	SN from	SN to	Mod.	Acces.	Volt	Description
Module:Solenoid valve group							
800	30001000		-				Solenoid valve
820	N.C.		-				Pression reducing valve

i=INSULATED HOOD, e=ELECTRONICAL CONTROL

130HE=130HE

lift=HOOD LIFTING SYSTEM, bt=BREAK TANK, bp=BOOSTER PUMP, dvgw=DVGW, ws=WATER SOFTNER, dd=DETERGENT DISPENSER, dp=DRAIN PUMP

A=3/N/PE~380-400V 50-60Hz, D=3/PE~200-210V 50-60Hz, F=2/PE~220-240V 50-60Hz, G=3/N/PE~415V 50-60Hz, H=3/PE~220-230V 50-60Hz, K=3/PE~380-400V 50-60Hz, L=3/PE~415V 50-60Hz, M=3/PE~440V 60Hz, P=1/N/PE~220-230V 50-60Hz, R=2/PE~220-240V 50-60Hz, U=1/N/PE~240V 50-60Hz, V=3/PE~240V 50-60Hz, W=1/N/PE~100-110V 50-60Hz



PLATON SERVICE

8 (800) 500-34-41

www.platonservice.com

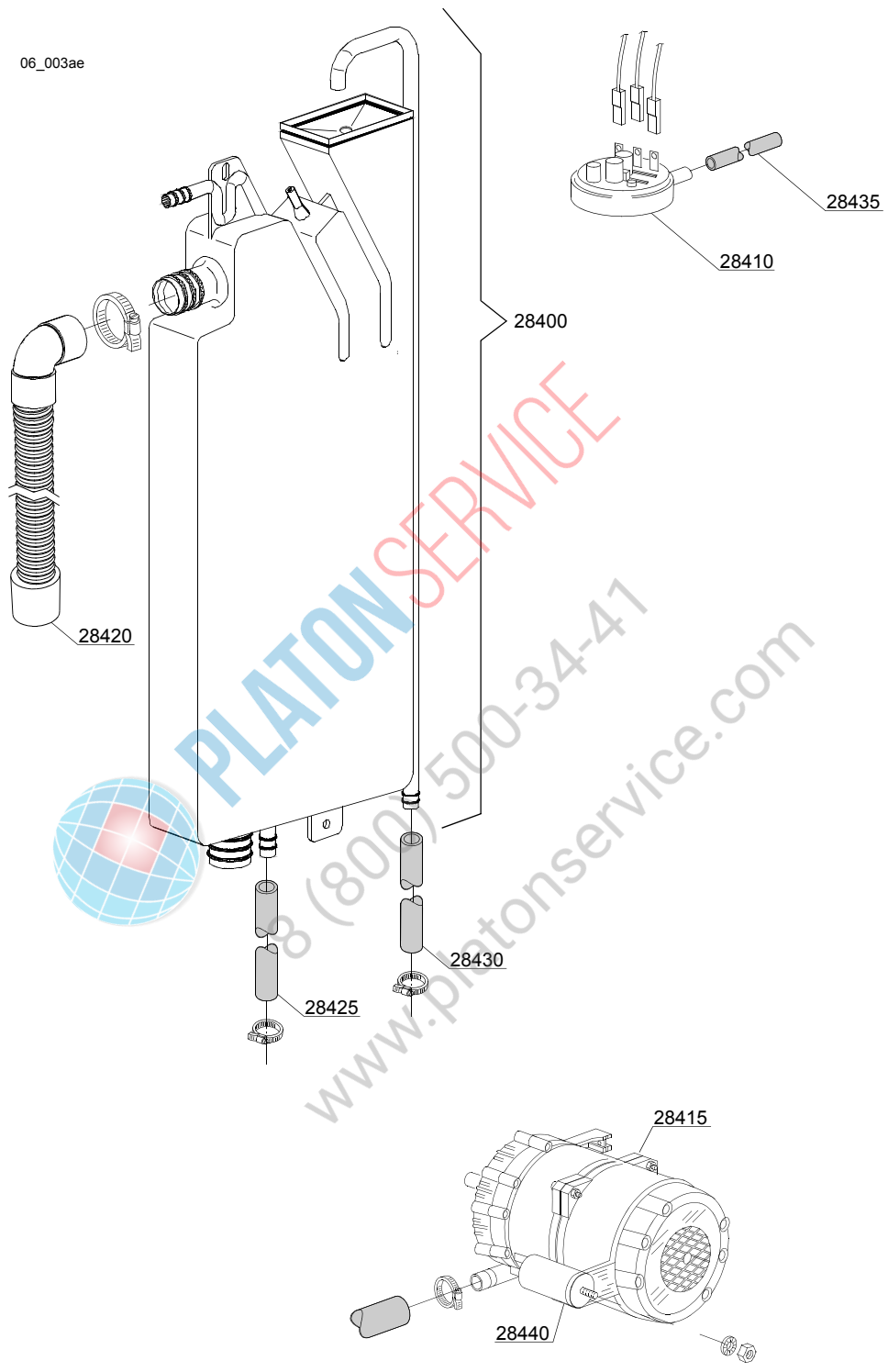

Spare parts

ID	P-code	SN from	SN to	Mod.	Acces.	Volt	Description
Module:Break Tank							
28400	15720		-		bt		Break tank assembly
28410	10706/A		-		bt		47-27 pressure switch
28415	15100/D		-		bt		Booster pump 220/240V - body pumps in plastic
28420	15721		-		bt		BT long pipe L=1070
28420	15722		-		bt		BT middle pipe L=920
28420	15723		-		bt		BT small pipe L=690
28425	2907350		-		bt		12x20 EPDM rubber hose
28430	2907352		-		bt		PVC WRAS rubber hose
28435	14508		-		bt		4,5x9 EPDM rubber hose
28440	10702		-		bt		5 uF condenser - 450V

i=INSULATED HOOD, e=ELECTRONICAL CONTROL

130HE=130HE

lift=HOOD LIFTING SYSTEM, bt=BREAK TANK, bp=BOOSTER PUMP, dvgw=DVGW, ws=WATER SOFTNER, dd=DETERGENT DISPENSER, dp=DRAIN PUMP

A=3/N/PE~380-400V 50-60Hz, D=3/PE~200-210V 50-60Hz, F=2/PE~220-240V 50-60Hz, G=3/N/PE~415V 50-60Hz, H=3/PE~220-230V 50-60Hz, K=3/PE~380-400V 50-60Hz, L=3/PE~415V 50-60Hz, M=3/PE~440V 60Hz, P=1/N/PE~220-230V 50-60Hz, R=2/PE~220-240V 50-60Hz, U=1/N/PE~240V 50-60Hz, V=3/PE~240V 50-60Hz, W=1/N/PE~100-110V 50-60Hz



PLATON SERVICE
8 (800) 500-34-41
www.platonservice.com

06_005_e

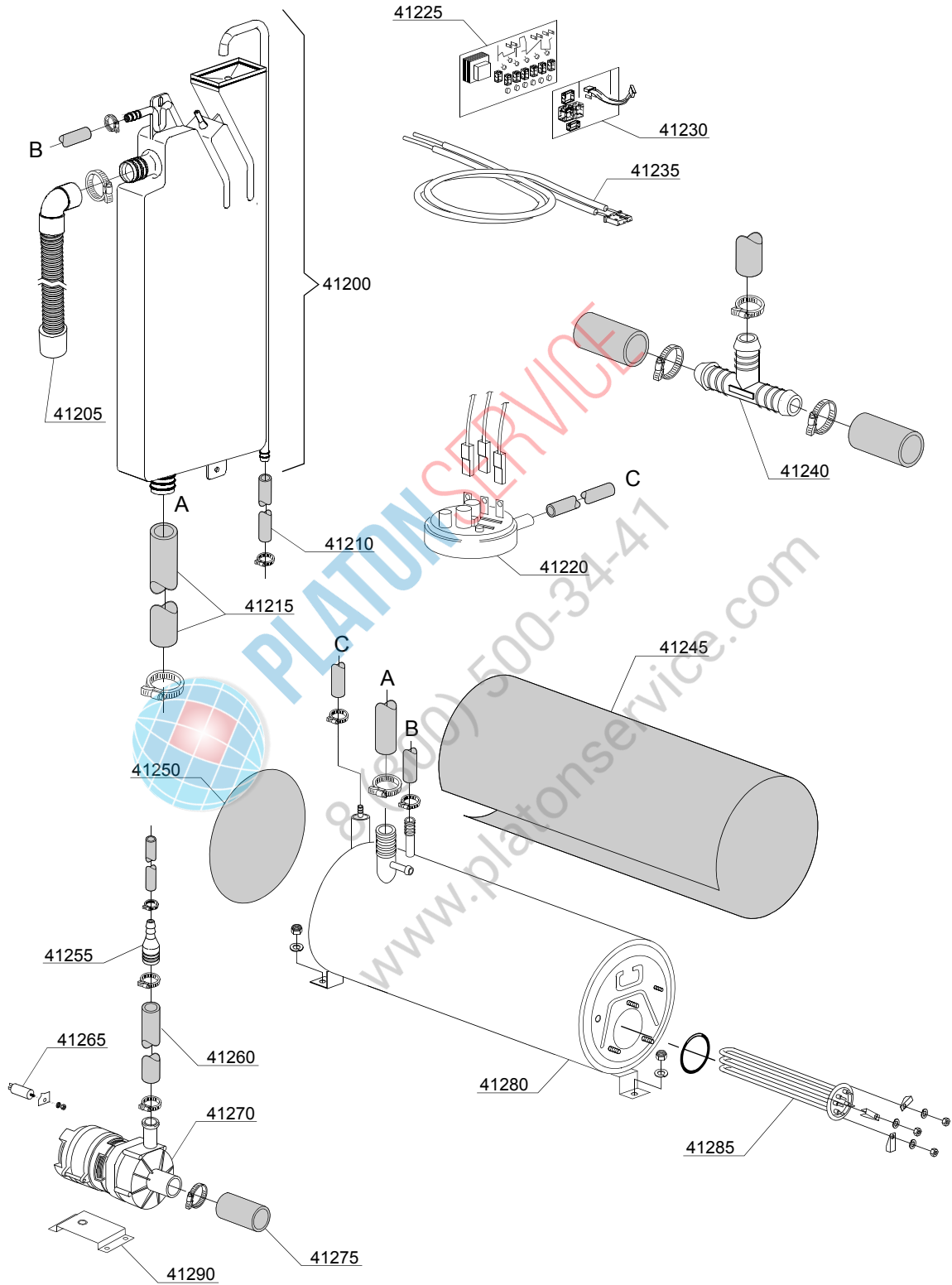

Spare parts

ID	P-code	SN from	SN to	Mod.	Acces.	Volt	Description
Module: Rinse with steady temperature							
41200	15720		-				Break tank assembly
41205	15721		-				BT middle pipe L=920
41210	2907352		-				PVC WRAS rubber hose
41215	x		-				Pipe coupling
41220	10706/A		-				34-100 pressure switch
41225	50569		-				Electronic Card without Chip
41230	50559		-				Circuit board DP
41235	50562		-				Sensor
41240	540098		-				3 ways D25
41245	30002030		-				Insulation boiler
41250	75205		-				Ø160 end piece
41255	3003063		-				Reducer
41260	10718		-				Pump pipe coupling
41265	10702		-				5 uF condenser
41270	10508		-				Rinsing pump
41275	10718		-				Pump pipe coupling
41280	11600104		-				Boiler
41285	30001011		-				Element 8,5kW
41290	440122		-				Pump support

i=INSULATED HOOD, e=ELECTRONICAL CONTROL

130HE=130HE

lift=HOOD LIFTING SYSTEM, bt=BREAK TANK, bp=BOOSTER PUMP, dvgw=DVGW, ws=WATER SOFTNER, dd=DETERGENT DISPENSER, dp=DRAIN PUMP

A=3/N/PE~380-400V 50-60Hz, D=3/PE~200-210V 50-60Hz, F=2/PE~220-240V 50-60Hz, G=3/N/PE~415V 50-60Hz, H=3/PE~220-230V 50-60Hz, K=3/PE~380-400V 50-60Hz, L=3/PE~415V 50-60Hz, M=3/PE~440V 60Hz, P=1/N/PE~220-230V 50-60Hz, R=2/PE~220-240V 50-60Hz, U=1/N/PE~240V 50-60Hz, V=3/PE~240V 50-60Hz, W=1/N/PE~100-110V 50-60Hz

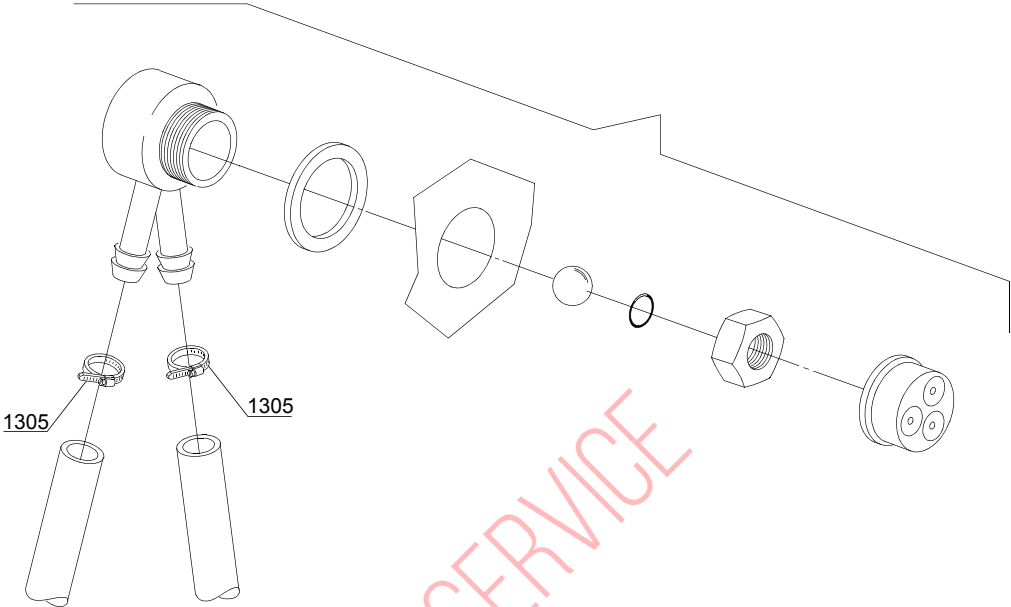

PLATON SERVICE

8 (800) 500-34-41

www.platonservice.com

08_005_e

Spare parts

ID	P-code	SN from	SN to	Mod.	Acces.	Volt	Description
Module:DVGW							
1300	999900006		-		dvgw		DVGW assembly
1305	11807		-		dvgw		Clamp 12/22

i=INSULATED HOOD, e=ELECTRONICAL CONTROL

130HE=130HE

lift=HOOD LIFTING SYSTEM, bt=BREAK TANK, bp=BOOSTER PUMP, dvgw=DVGW, ws=WATER SOFTNER, dd=DETERGENT DISPENSER, dp=DRAIN PUMP

A=3/N/PE~380-400V 50-60Hz, D=3/PE~200-210V 50-60Hz, F=2/PE~220-240V 50-60Hz, G=3/N/PE~415V 50-60Hz, H=3/PE~220-230V 50-60Hz, K=3/PE~380-400V 50-60Hz, L=3/PE~415V 50-60Hz, M=3/PE~440V 60Hz, P=1/N/PE~220-230V 50-60Hz, R=2/PE~220-240V 50-60Hz, U=1/N/PE~240V 50-60Hz, V=3/PE~240V 50-60Hz, W=1/N/PE~100-110V 50-60Hz



PLATON SERVICE

8 (800) 500-34-41

www.platonservice.com

09_001_e

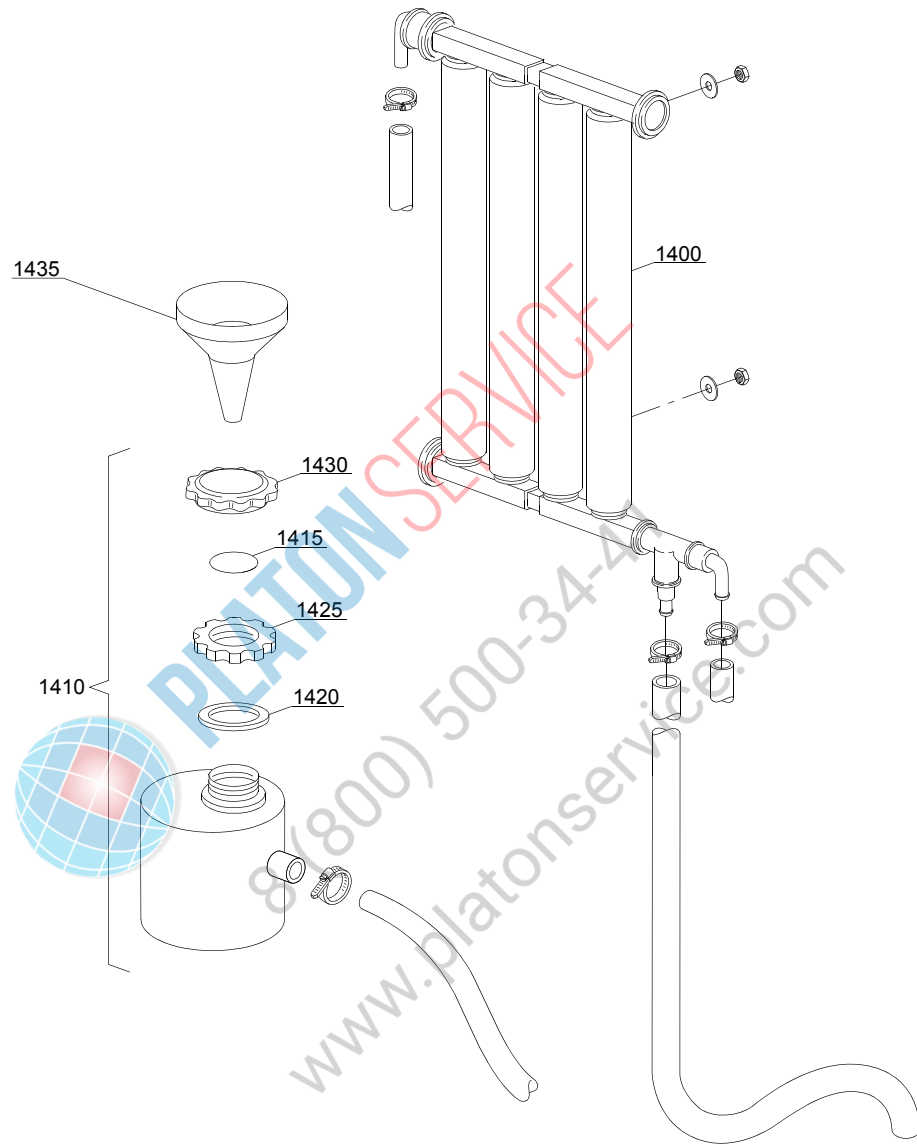

Spare parts

ID	P-code	SN from	SN to	Mod.	Acces.	Volt	Description
Module: Water softner group							
1400	16066		-		ws		4 elements water softner
1405	16070		-		ws		Nonreturn valve
1410	16065		-		ws		Salt container
1415	16067/A		-		ws		OR O-ring
1420	16067/B		-		ws		O-ring
1425	16067/C		-		ws		Ring nut
1430	16067/D		-		ws		Plug
1435	16082		-		ws		Funnel

i=INSULATED HOOD, e=ELECTRONICAL CONTROL

130HE=130HE

lift=HOOD LIFTING SYSTEM, bt=BREAK TANK, bp=BOOSTER PUMP, dvgw=DVGW, ws=WATER SOFTNER, dd=DETERGENT DISPENSER, dp=DRAIN PUMP

A=3/N/PE~380-400V 50-60Hz, D=3/PE~200-210V 50-60Hz, F=2/PE~220-240V 50-60Hz, G=3/N/PE~415V 50-60Hz, H=3/PE~220-230V 50-60Hz, K=3/PE~380-400V 50-60Hz, L=3/PE~415V 50-60Hz, M=3/PE~440V 60Hz, P=1/N/PE~220-230V 50-60Hz, R=2/PE~220-240V 50-60Hz, U=1/N/PE~240V 50-60Hz, V=3/PE~240V 50-60Hz, W=1/N/PE~100-110V 50-60Hz



PLATON SERVICE
8 (800) 500-34-41
www.platonservice.com

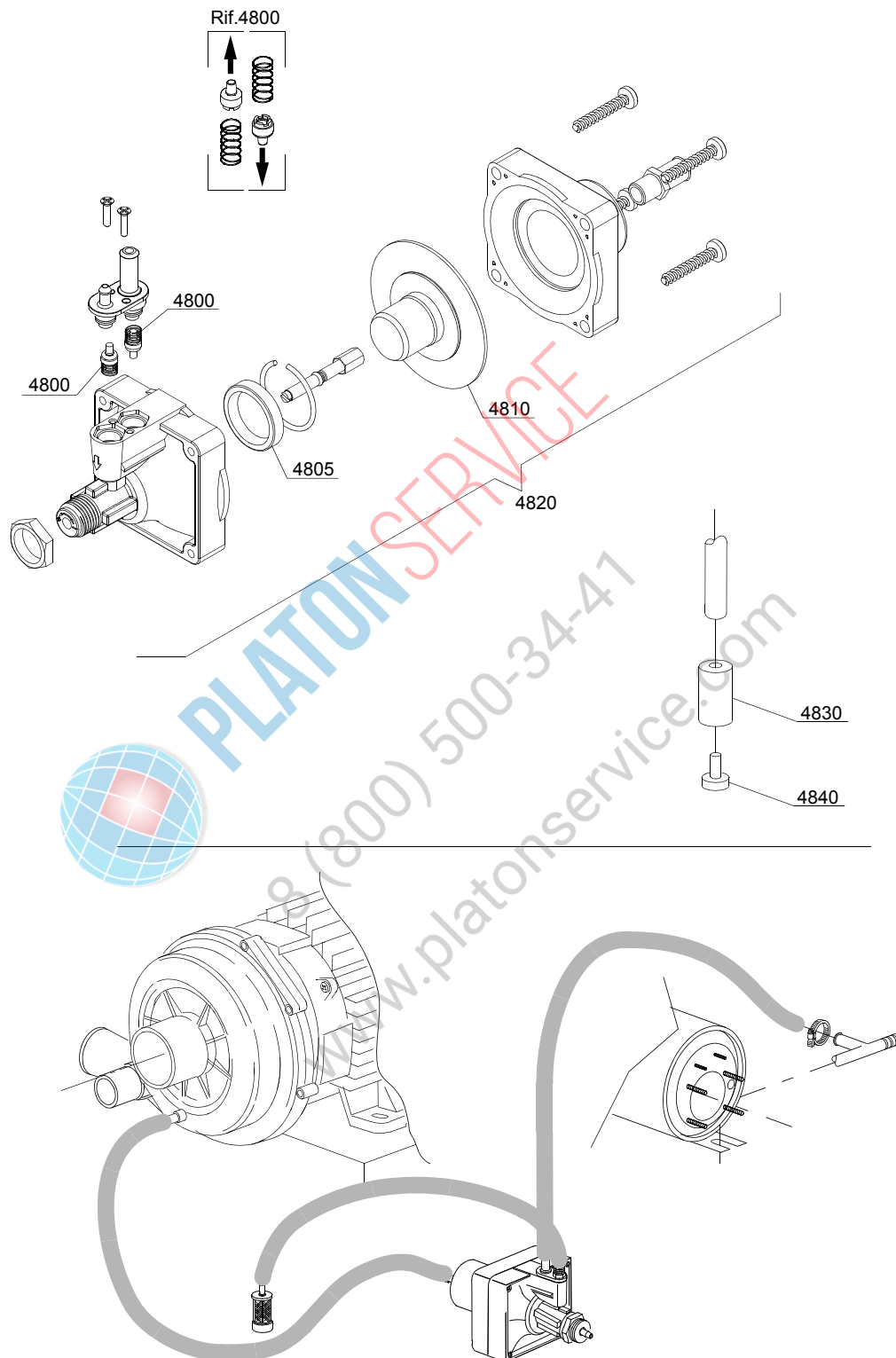

10_004ae

Spare parts

ID	P-code	SN from	SN to	Mod.	Acces.	Volt	Description
Module: Rinse aid dispenser group							
4800	10805		-	i			Tecnopro non return valve
4805	10806		-	i			Ø22 O-ring
4810	10807		-	i			Membrane
4820	10799		-	i			Rinse aid dispenser
4830	12525		-	i			Counter-weight
4840	15058		-	i			Small filter

i=INSULATED HOOD, e=ELECTRONICAL CONTROL

130HE=130HE

lift=HOOD LIFTING SYSTEM, bt=BREAK TANK, bp=BOOSTER PUMP, dvgw=DVGW, ws=WATER SOFTNER, dd=DETERGENT DISPENSER, dp=DRAIN PUMP

A=3/N/PE~380-400V 50-60Hz, D=3/PE~200-210V 50-60Hz, F=2/PE~220-240V 50-60Hz, G=3/N/PE~415V 50-60Hz, H=3/PE~220-230V 50-60Hz, K=3/PE~380-400V 50-60Hz, L=3/PE~415V 50-60Hz, M=3/PE~440V 60Hz, P=1/N/PE~220-230V 50-60Hz, R=2/PE~220-240V 50-60Hz, U=1/N/PE~240V 50-60Hz, V=3/PE~240V 50-60Hz, W=1/N/PE~100-110V 50-60Hz



PLATON SERVICE
8 (800) 500-34-41
www.platonservice.com

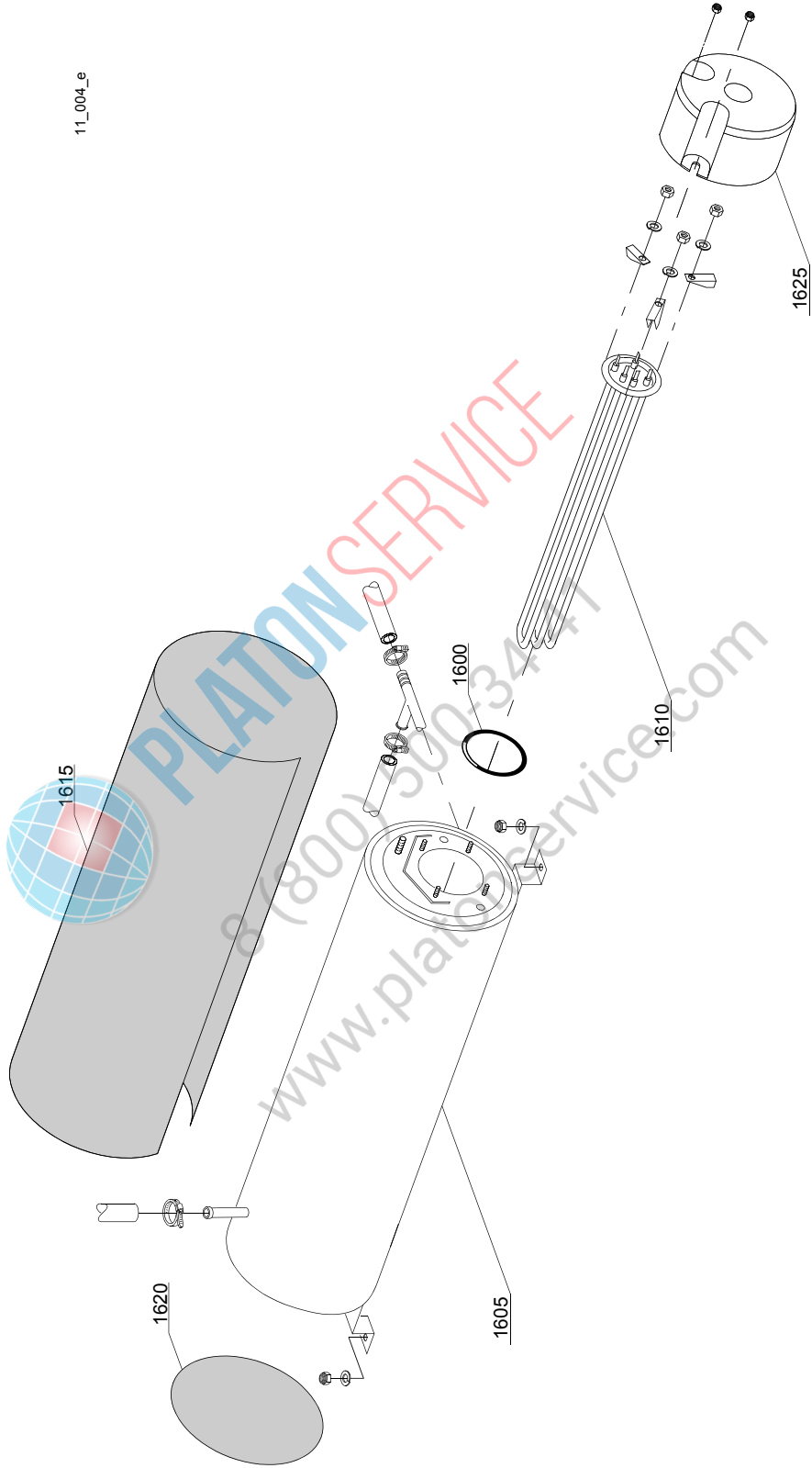

Spare parts

ID	P-code	SN from	SN to	Mod.	Acces.	Volt	Description
Module:Boiler group							
1600	13015		-				O-ring
1605	22002		-				Boiler
1610	30001011		-				Element 9kW
1615	30002030		-				Insulation boiler
1620	75205		-				Ø160 end piece
1625	75311		-				Heating element cover

i=INSULATED HOOD, e=ELECTRONICAL CONTROL

130HE=130HE

lift=HOOD LIFTING SYSTEM, bt=BREAK TANK, bp=BOOSTER PUMP, dvgw=DVGW, ws=WATER SOFTNER, dd=DETERGENT DISPENSER, dp=DRAIN PUMP

A=3/N/PE~380-400V 50-60Hz, D=3/PE~200-210V 50-60Hz, F=2/PE~220-240V 50-60Hz, G=3/N/PE~415V 50-60Hz, H=3/PE~220-230V 50-60Hz, K=3/PE~380-400V 50-60Hz, L=3/PE~415V 50-60Hz, M=3/PE~440V 60Hz, P=1/N/PE~220-230V 50-60Hz, R=2/PE~220-240V 50-60Hz, U=1/N/PE~240V 50-60Hz, V=3/PE~240V 50-60Hz, W=1/N/PE~100-110V 50-60Hz



PLATON SERVICE
8 (800) 500-34-41
www.platonservice.com

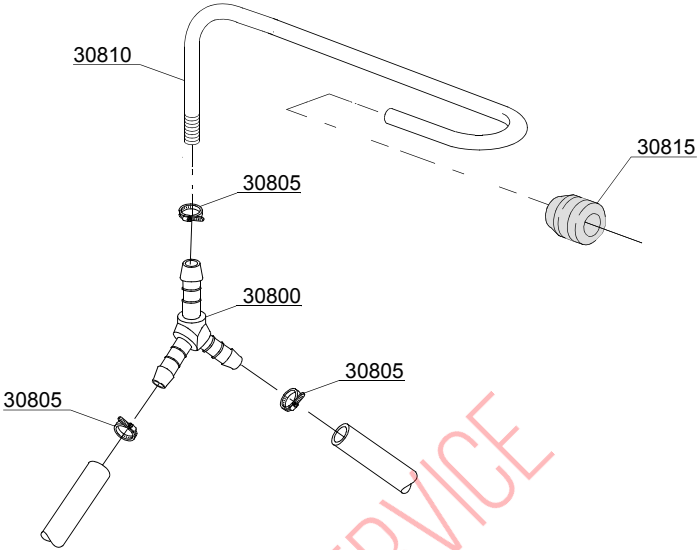

12_003_e



PLATON SERVICE

8 (800) 500-34-41

www.platonservice.com

Spare parts

ID	P-code	SN from	SN to	Mod.	Acces.	Volt	Description
Module:3 ways connection							
30800	540091		-	i			Ø12 mm plastic 3 ways connection
30805	11807		-	i			Clamp
30810	76082		-	i			Rinse pipe
30815	13304		-	i			Pipe

i=INSULATED HOOD, e=ELECTRONICAL CONTROL

130HE=130HE

lift=HOOD LIFTING SYSTEM, bt=BREAK TANK, bp=BOOSTER PUMP, dvgw=DVGW, ws=WATER SOFTNER, dd=DETERGENT DISPENSER, dp=DRAIN PUMP

A=3/N/PE~380-400V 50-60Hz, D=3/PE~200-210V 50-60Hz, F=2/PE~220-240V 50-60Hz, G=3/N/PE~415V 50-60Hz, H=3/PE~220-230V 50-60Hz, K=3/PE~380-400V 50-60Hz, L=3/PE~415V 50-60Hz, M=3/PE~440V 60Hz, P=1/N/PE~220-230V 50-60Hz, R=2/PE~220-240V 50-60Hz, U=1/N/PE~240V 50-60Hz, V=3/PE~240V 50-60Hz, W=1/N/PE~100-110V 50-60Hz



PLATON SERVICE
 8 (800) 500-34-41
 www.platonservice.com

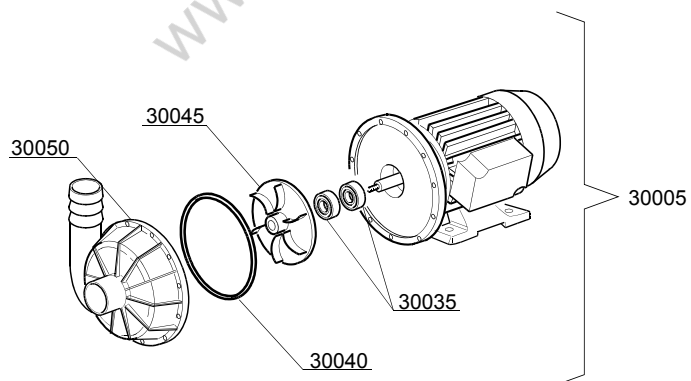
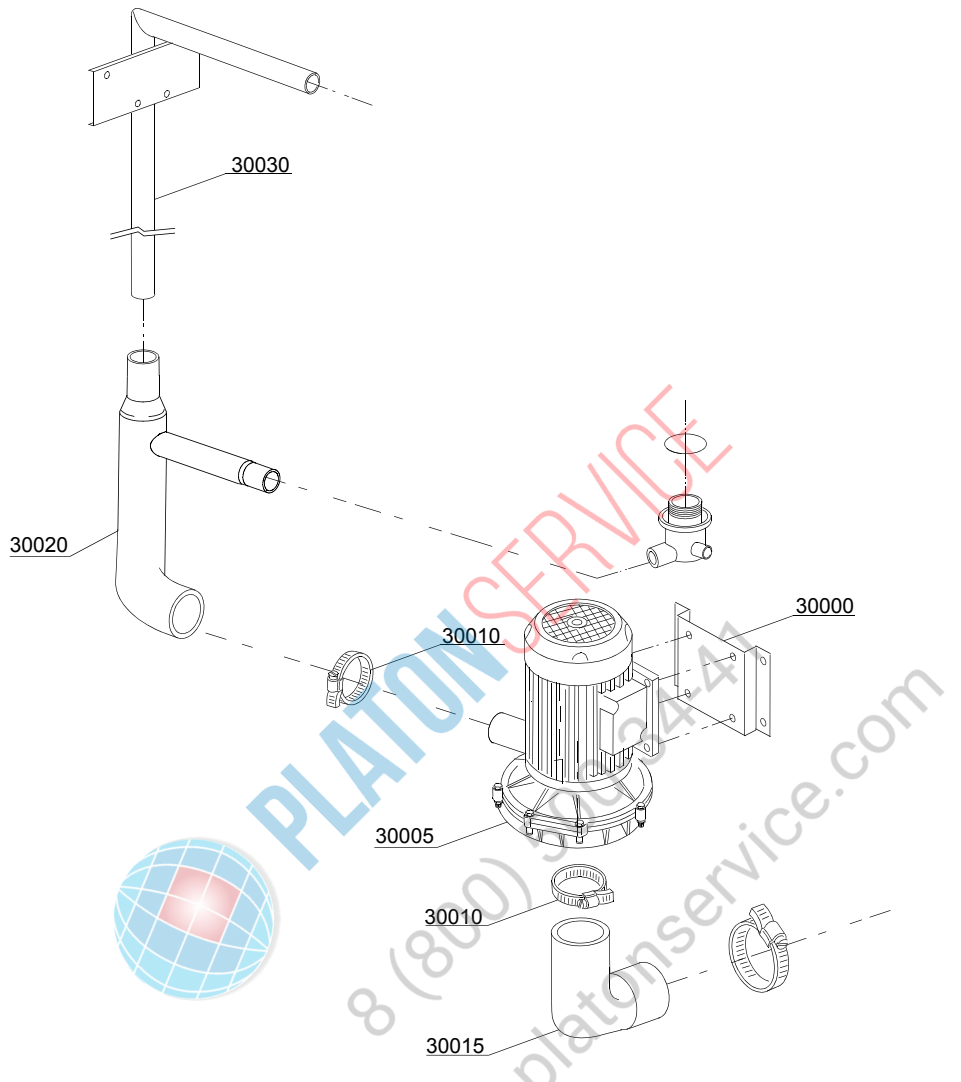

13_120_e

Spare parts

ID	P-code	SN from	SN to	Mod.	Acces.	Volt	Description
Module: Wash pump group							
30005	22037		-	e			2Hp pump 230/380/415 3Fh 50Hz
30010	11824		-	e			50/70 Clamp
30015	11600100		-	e			Suction pipe coupling
30020	11600101		-	e			Pressure rubber hose
30025	11809		-	e			30/45 Clamp
30030	11600103		-	e			Wash ramp
30035	15080		-	e			Rotating seals
30040	10200290		-	e			OR 1225 O-ring
30045	22045		-	e			Pump rotor (pump 2Hp)
30050	10200222		-	e			Scroll

i=INSULATED HOOD, e=ELECTRONICAL CONTROL

130HE=130HE

lift=HOOD LIFTING SYSTEM, bt=BREAK TANK, bp=BOOSTER PUMP, dvgw=DVGW, ws=WATER SOFTNER, dd=DETERGENT DISPENSER, dp=DRAIN PUMP

A=3/N/PE~380-400V 50-60Hz, D=3/PE~200-210V 50-60Hz, F=2/PE~220-240V 50-60Hz, G=3/N/PE~415V 50-60Hz, H=3/PE~220-230V 50-60Hz, K=3/PE~380-400V 50-60Hz, L=3/PE~415V 50-60Hz, M=3/PE~440V 60Hz, P=1/N/PE~220-230V 50-60Hz, R=2/PE~220-240V 50-60Hz, U=1/N/PE~240V 50-60Hz, V=3/PE~240V 50-60Hz, W=1/N/PE~100-110V 50-60Hz



PLATON SERVICE
8 (800) 500-34-41
www.platonservice.com

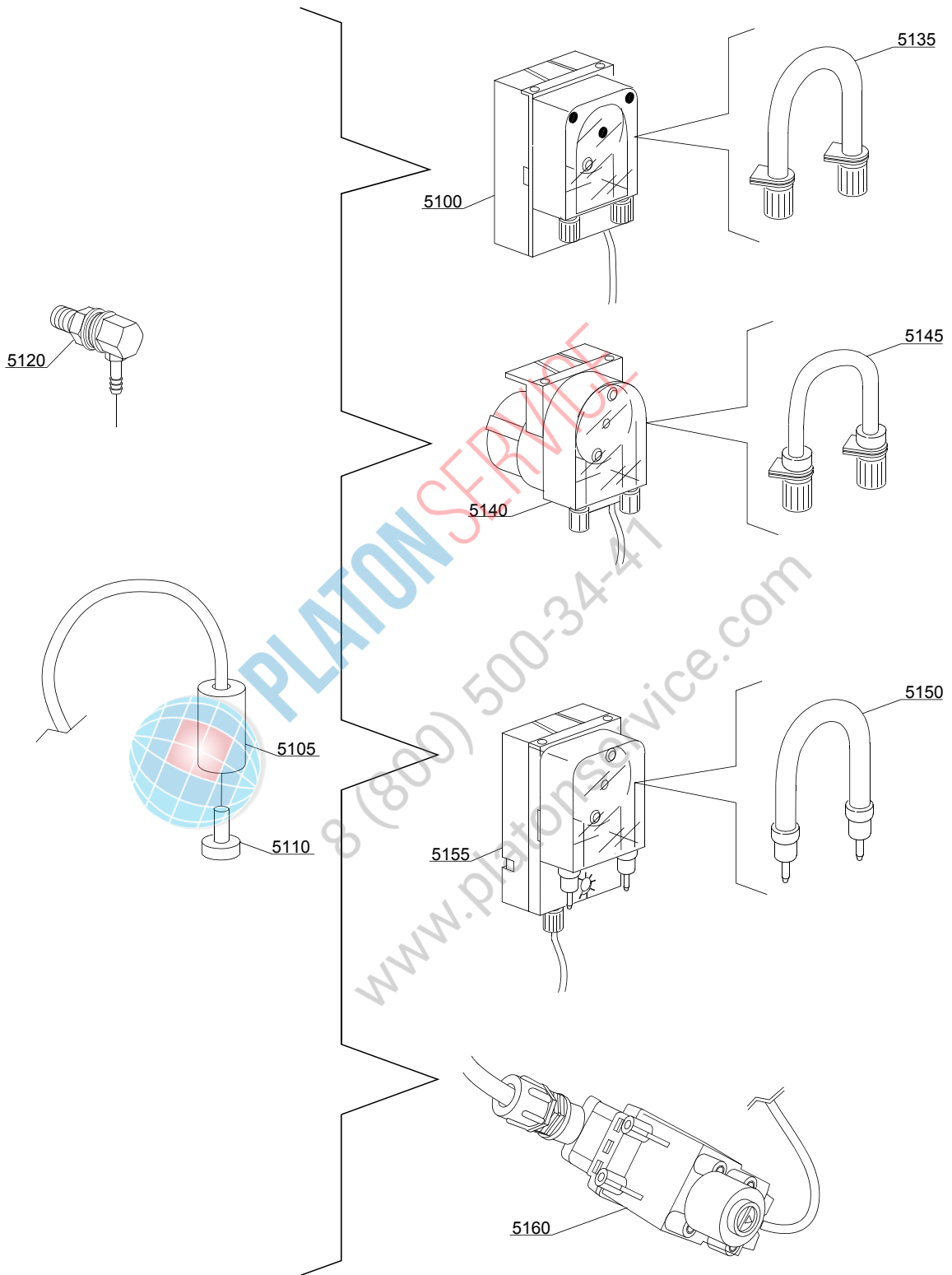

14_004_e

Spare parts

ID	P-code	SN from	SN to	Mod.	Acces.	Volt	Description
Module:Dosing detergent group							
5100	15985		-	i	dd		Seko detergent pump
5105	12525		-	i	dd		Counter-weight
5110	15058		-	i	dd		Small filter
5120	15123		-	i	dd		Steel injector
5125	15159		-	i	dd		OR O-ring
5130	10200205		-	i	dd		M12x1 stainless steel nut
5135	15185		-	i	dd		Seko thermoplastic pipe Ø 10
5140	15985		-	i	dd		Germac detergent pump
5145	15108/E		-	i	dd		Germac thermoplastic pipe Ø 8
5150	15985/A		-	i	dd		Ø 10 PLAS CONT thermoplastic pipe
5155	15985		-	i	dd		PLAS CONT detergent pump
5160	15108/L		-	i	dd		LANG detergent pump

i=INSULATED HOOD, e=ELECTRONICAL CONTROL

130HE=130HE

lift=HOOD LIFTING SYSTEM, bt=BREAK TANK, bp=BOOSTER PUMP, dvgw=DVGW, ws=WATER SOFTNER, dd=DETERGENT DISPENSER, dp=DRAIN PUMP

A=3/N/PE~380-400V 50-60Hz, D=3/PE~200-210V 50-60Hz, F=2/PE~220-240V 50-60Hz, G=3/N/PE~415V 50-60Hz, H=3/PE~220-230V 50-60Hz, K=3/PE~380-400V 50-60Hz, L=3/PE~415V 50-60Hz, M=3/PE~440V 60Hz, P=1/N/PE~220-230V 50-60Hz, R=2/PE~220-240V 50-60Hz, U=1/N/PE~240V 50-60Hz, V=3/PE~240V 50-60Hz, W=1/N/PE~100-110V 50-60Hz



PLATON SERVICE
8 (800) 500-3477
www.platonservice.com

15_005_e

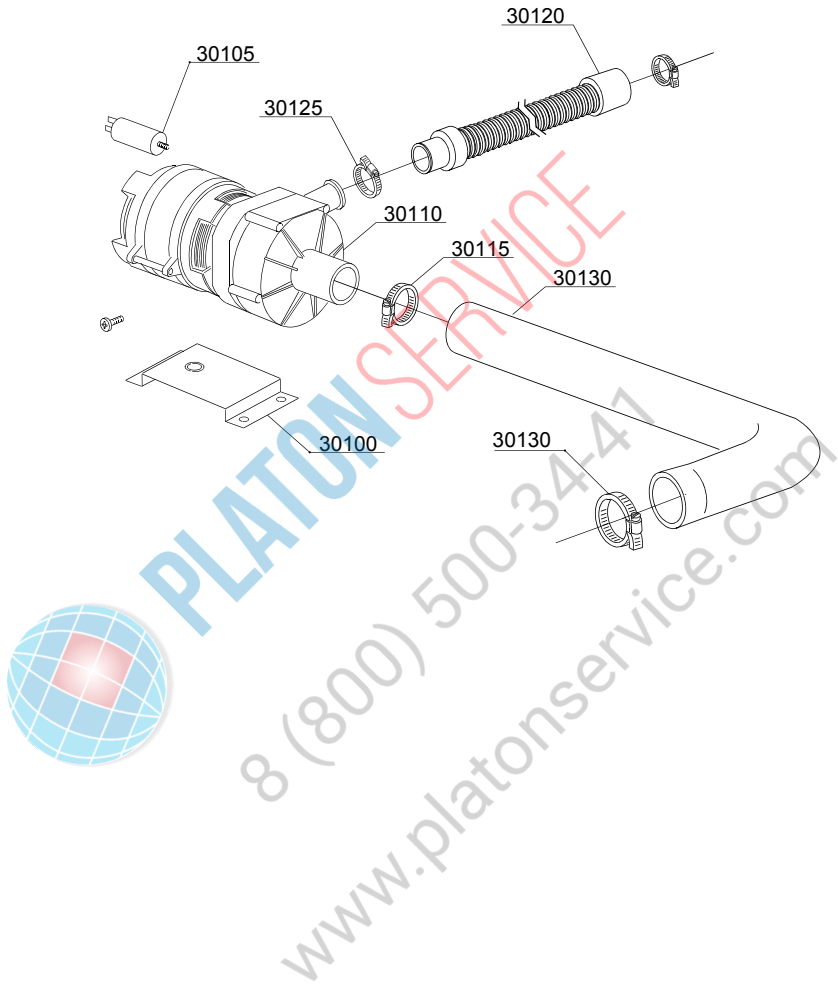

Spare parts

ID	P-code	SN from	SN to	Mod.	Acces.	Volt	Description
Module: Drain pump group							
30100	440122		-		dp		Pump support
30105	10702		-		dp		5 uF condenser
30110	10501/A		-		dp		Drain pump (extra equipment)
30115	11806		-		dp		25/40 clamp
30120	10727		-		dp		Drain pipe
30125	11809		-		dp		Clamp
30130	18788		-		dp		Drain rubber elbow

i=INSULATED HOOD, e=ELECTRONICAL CONTROL

130HE=130HE

lift=HOOD LIFTING SYSTEM, bt=BREAK TANK, bp=BOOSTER PUMP, dvgw=DVGW, ws=WATER SOFTNER, dd=DETERGENT DISPENSER, dp=DRAIN PUMP

A=3/N/PE~380-400V 50-60Hz, D=3/PE~200-210V 50-60Hz, F=2/PE~220-240V 50-60Hz, G=3/N/PE~415V 50-60Hz, H=3/PE~220-230V 50-60Hz, K=3/PE~380-400V 50-60Hz, L=3/PE~415V 50-60Hz, M=3/PE~440V 60Hz, P=1/N/PE~220-230V 50-60Hz, R=2/PE~220-240V 50-60Hz, U=1/N/PE~240V 50-60Hz, V=3/PE~240V 50-60Hz, W=1/N/PE~100-110V 50-60Hz



PLATON SERVICE
8 (800) 500-34-41
www.platonservice.com

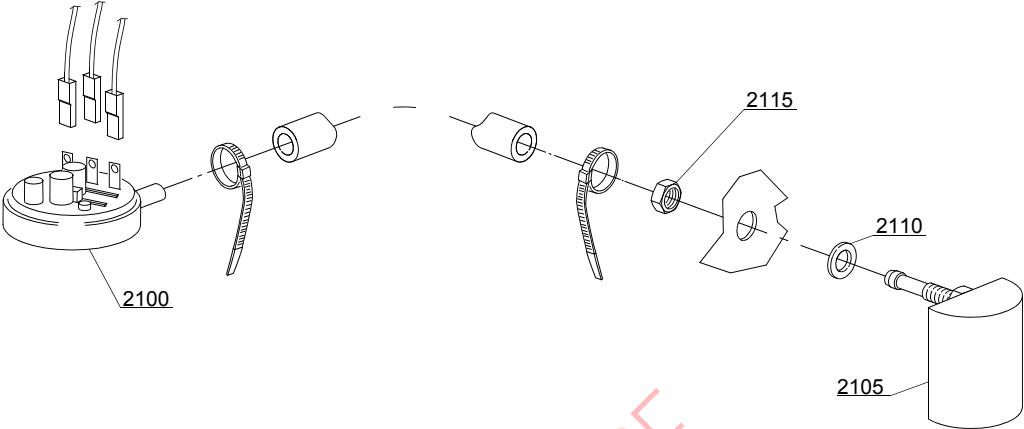

 **PLATON SERVICE**
8 (800) 500-34-41
www.platonservice.com

16_001_e

Spare parts

ID	P-code	SN from	SN to	Mod.	Acces.	Volt	Description
Module:Pressure switch group with air trap							
2100	88110		-				Pressure switch PR
2105	135911		-				Air trap
2110	13301		-	i			Gasket
2115	11702		-	i			Nut

i=INSULATED HOOD, e=ELECTRONICAL CONTROL

130HE=130HE

lift=HOOD LIFTING SYSTEM, bt=BREAK TANK, bp=BOOSTER PUMP, dvgw=DVGW, ws=WATER SOFTNER, dd=DETERGENT DISPENSER, dp=DRAIN PUMP

A=3/N/PE~380-400V 50-60Hz, D=3/PE~200-210V 50-60Hz, F=2/PE~220-240V 50-60Hz, G=3/N/PE~415V 50-60Hz, H=3/PE~220-230V 50-60Hz, K=3/PE~380-400V 50-60Hz, L=3/PE~415V 50-60Hz, M=3/PE~440V 60Hz, P=1/N/PE~220-230V 50-60Hz, R=2/PE~220-240V 50-60Hz, U=1/N/PE~240V 50-60Hz, V=3/PE~240V 50-60Hz, W=1/N/PE~100-110V 50-60Hz



PLATON SERVICE
8 (800) 500-34-41
www.platonservice.com

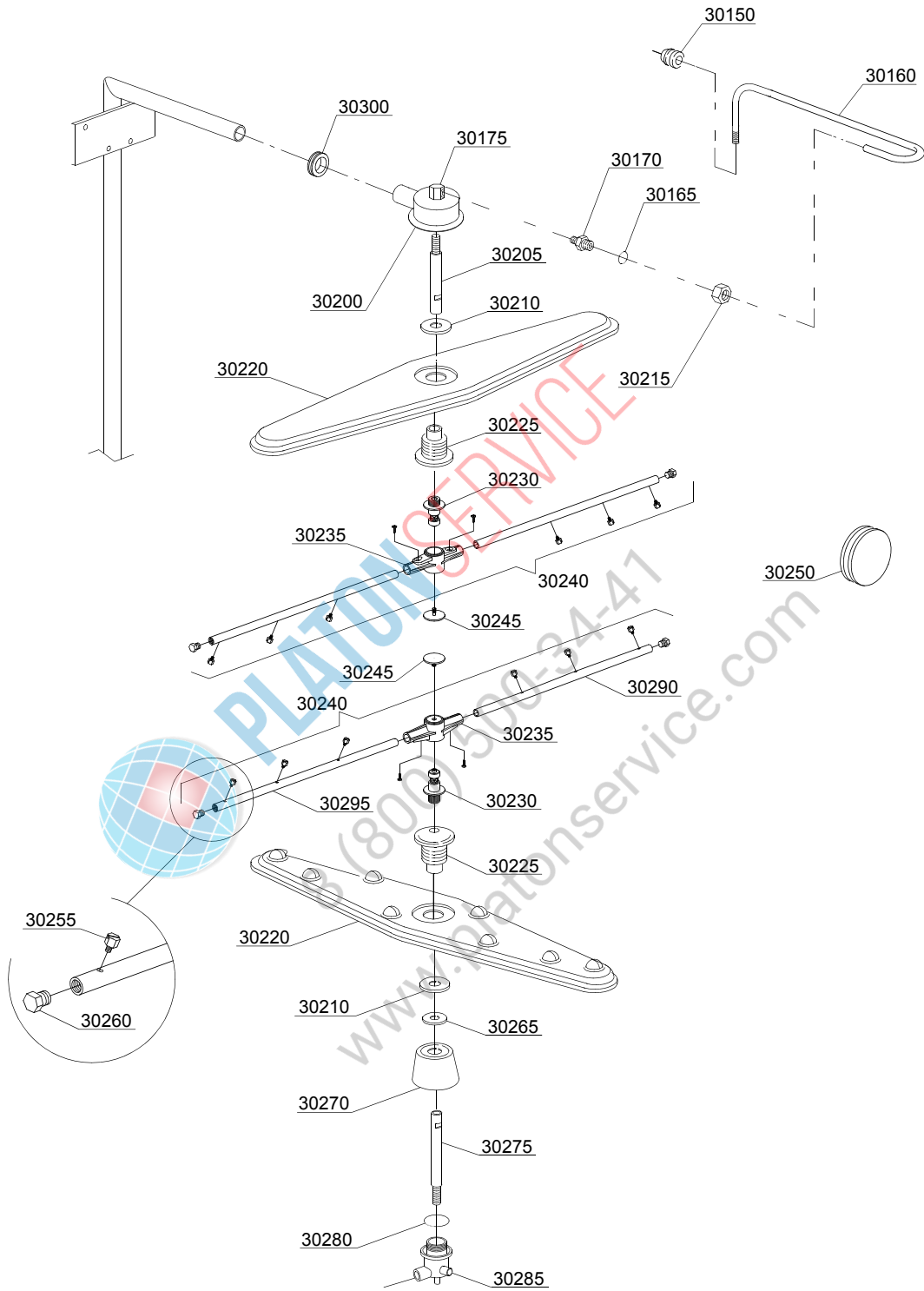

17_125ae

Spare parts

ID	P-code	SN from	SN to	Mod.	Acces.	Volt	Description
Module:Turret group with rotating arms							
30150	13304	4025782	-	e			Pipe
30160	76082	4025782	-	e			Pipe gasket
30165	13003		-	e			OR 112 NBR O-ring
30170	12006		-	e			Coupling
30175	75319		-	e			Elbow coupling
30200	78001		-	e			Distributor upper
30205	75322		-	e			Shaft, upper
30210	75317		-	e			Nut
30215	12006/A		-	e			Ø10 pipe fitting 3/8x3,5 nut 19 hexagonal
30220	10600900		-	e			Wash arm
30225	75320		-	e			Holder
30230	10651		-	e			Rinse axle
30235	10650		-	e			Rinse arm
30240	75918		-	e			Rinse arm, compl.
30245	10652		-	e			Rinse arm screw
30250	13316/A		-	e			DVGW hole O-ring
30255	560018		-	e			Nozzle
30260	560017		-	e			Plug
30265	11600033		-	e			Ring
30270	11600007		4025334	e			Support
30270	11600035	4025335		e			Lower wash arm support
30275	11600021			e			Shaft, lower
30280	13015		-	e			O-ring
30285	500621		-	e			Distributor lower
30290	10657		-	e			Right rinse arm - stainless steel nozzle
30295	10658		-	e			Left rinse arm - stainless steel nozzle
30300	76081	4025782	-	e			Pipe-pass O-ring 51x34x14

i=INSULATED HOOD, e=ELECTRONICAL CONTROL

130HE=130HE

lift=HOOD LIFTING SYSTEM, bt=BREAK TANK, bp=BOOSTER PUMP, dvgw=DVGW, ws=WATER SOFTNER, dd=DETERGENT DISPENSER, dp=DRAIN PUMP

A=3/N/PE~380-400V 50-60Hz, D=3/PE~200-210V 50-60Hz, F=2/PE~220-240V 50-60Hz, G=3/N/PE~415V 50-60Hz, H=3/PE~220-230V 50-60Hz, K=3/PE~380-400V 50-60Hz, L=3/PE~415V 50-60Hz, M=3/PE~440V 60Hz, P=1/N/PE~220-230V 50-60Hz, R=2/PE~220-240V 50-60Hz, U=1/N/PE~240V 50-60Hz, V=3/PE~240V 50-60Hz, W=1/N/PE~100-110V 50-60Hz